

# T6INNVPEDS

6' INNOVATED PEDESTAL TABLE  
INGROUND MOUNT DESIGN

## **FURNITURE LEISURE INC**

### OUR LIST OF WEB STORES

[www.FurnitureLeisure.com](http://www.FurnitureLeisure.com)  
[www.PicnicFurniture.com](http://www.PicnicFurniture.com)  
[www.ParkTables.com](http://www.ParkTables.com)

[www.PoolFurnitureSupply.com](http://www.PoolFurnitureSupply.com)  
[www.PicnicTableSupplier.com](http://www.PicnicTableSupplier.com)  
[www.UBrace.com](http://www.UBrace.com)

**1.800.213.2401**

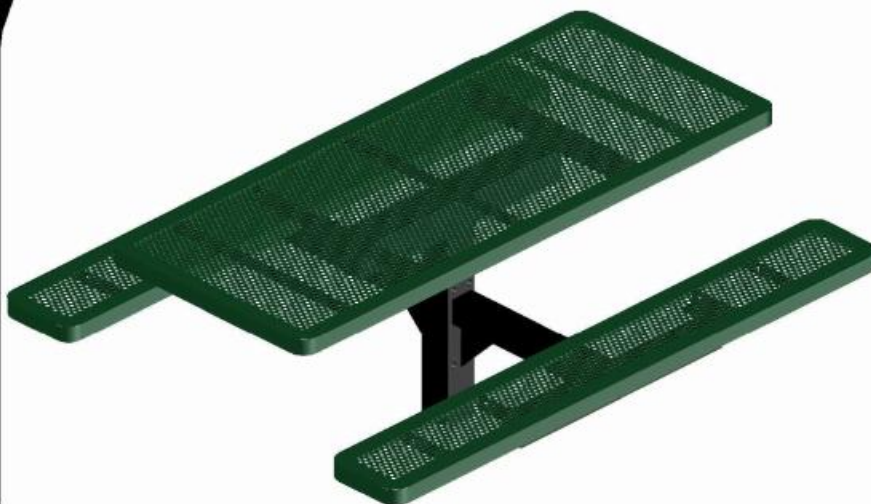

Please take the time to locate and identify each part. Assemble the units on a smooth flat surface. It is also helpful to lay the tops and seats on cardboard or a drop cloth to prevent scratching of the surface during assembly. All parts have been pre-cut and pre-drilled for ease of assembly. All holes are slotted to allow for easy assembly and for final levelling of tops and seats to frames. Fully assemble all parts without totally tightening nuts and bolts. After all assembled go back and retighten nuts to bolts. **DO NOT OVER TIGHTEN NUTS TO BOLTS.** Over tightened nuts can crack the plastisol coating. All the necessary quantities of parts required are listed in this assembly instructions.

**DO NOT BEGIN ASSEMBLY UNTIL YOU HAVE READ THESE INSTRUCTIONS AND ARE FAMILIAR WITH THE PARTS.**

# PARTS IDENTIFICATION

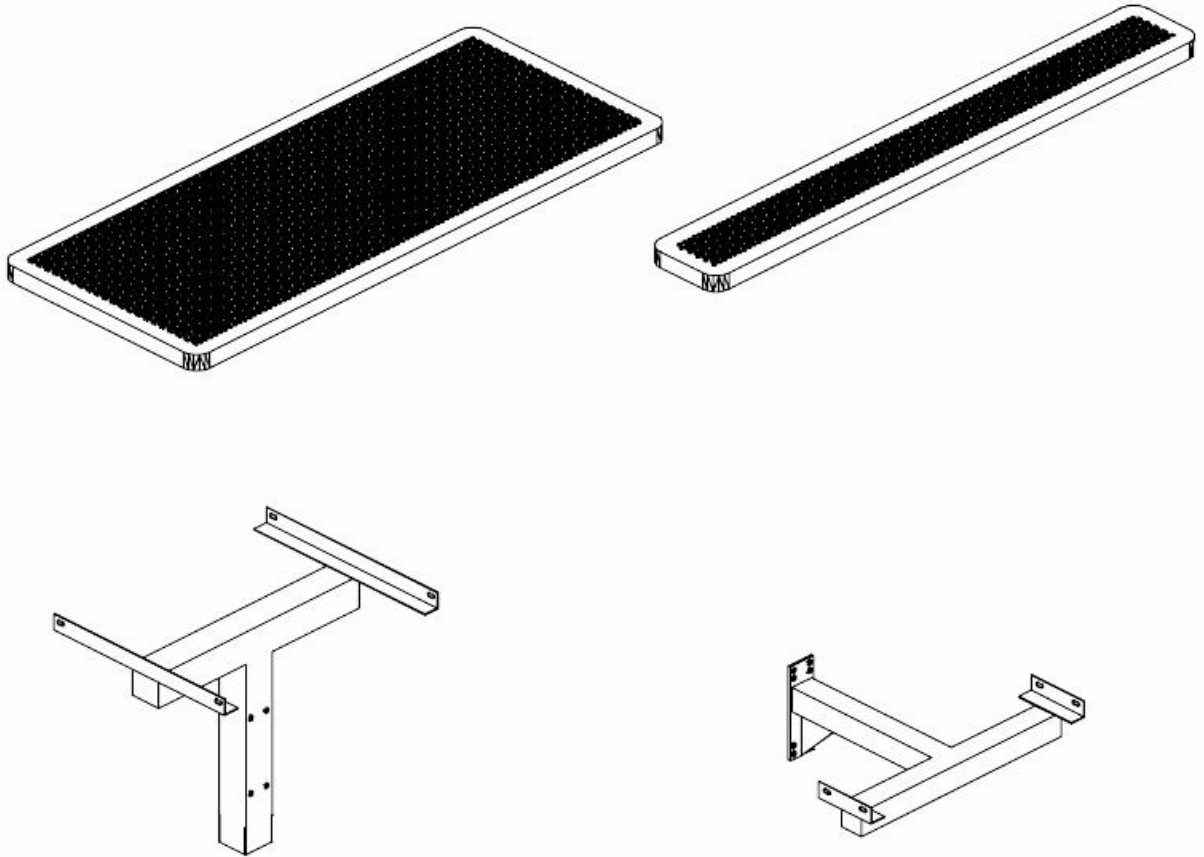

## PARTS LIST

ITEM	PART#	DESCRIPTION	QTY.
A	TT6INNVPED	6' INNVPE TOP	1
B	S6INNVPED	6' INNVPE SEAT	2
C	F6PEDCPI	CENTER POST	1
D	F6PEDARM	PEDESTAL ARMS	2

ITEM	HARDWARE DESCRIPTION	QTY.
HW1	5/16" X 18 NYL LOCKNUTS	12
HW2	5/16" X 18GA CAP BOLTS	12
HW3	5/16" FLAT WASHERS	24
HW4	BOLT GUARDS	12
HW5	5/8" BOLTS	4
HW6	5/8" NUTS	4

ASSEMBLY TOOLS REQUIRED  
2- 1/2" WRENCHES

## HARDWARE IDENTIFICATION



(HW1) 5/16" X 18  
NYL LOCKNUTS

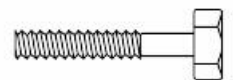

(HW2) 5/16" X 18  
GAUGE CAP BOLTS



(HW5) 5/8" NUTS



(HW3) 5/16"  
FLAT WASHERS



(HW4) BOLT  
GUARDS



(HW6) 5/8" BOLTS

# ASSEMBLY PROCEDURES

## STEP 1

DIG A FOOTING HOLE 24" SQUARE TO ALLOW FOR 18" OF INGROUND INSTULATION OF PEDESTAL STAND. SET PEDESTAL STAND 18" IN FOOTING HOLE AND PROP IN A PLUMB AND LEVEL POSITION.

**POUR CONCRETE AND LET STAND FOR 24 HOURS BEFORE COMPLETING THESE ASSEMBLY INSTRUCTIONS.**

## STEP 2

BOLT THE 2 ARMS TO THE CENTER PEDESTAL USING 5/8" X 5 1/2" BOLTS & 5/8" NYLOCK NUTS. TIGHTEN BOLTS UP TIGHT.

## STEP 3

MOUNT TOP ON CENTER PEDESTAL POST BY MATCHING UP THE HOLES ON BRACES OF THE TOP TO THE HOLES IN THE 2" x 2" ANGLE IRON ON THE POST. MOUNT BY MEANS OF FOUR 5/16" X 1 1/2" CAP BOLTS, EIGHT 5/16" FLAT WASHERS, AND FOUR 5/16" NYLOCK NUTS.

## STEP 4

SET EACH OF THE TWO SEATS ON THE SEAT BRACKETS OF THE PEDESTAL ARMS. MATCHING UP THE TWO ARMS UNDER THE SEATS WITH FOUR HOLES ON THE ANGLE IRON BRACE OF THE ARMS. MOUNT BY MEANS OF EIGHT 5/16" X 1 1/2" CAP BOLTS, SIXTEEN 5/16" FLAT WASHERS, AND EIGHT 5/16" NYLOCK NUTS.

## STEP 5

TIGHTEN ALL NUTS ON BOLTS AND PLACE BOLT GUARDS ON ALL NUTS. DO NOT OVER TIGHTEN AS THIS COULD CAUSE THE PLASTISOL COATING TO CRACK.

1	CAP BOLT & WASHER
2	WASHER & LOCK NUT

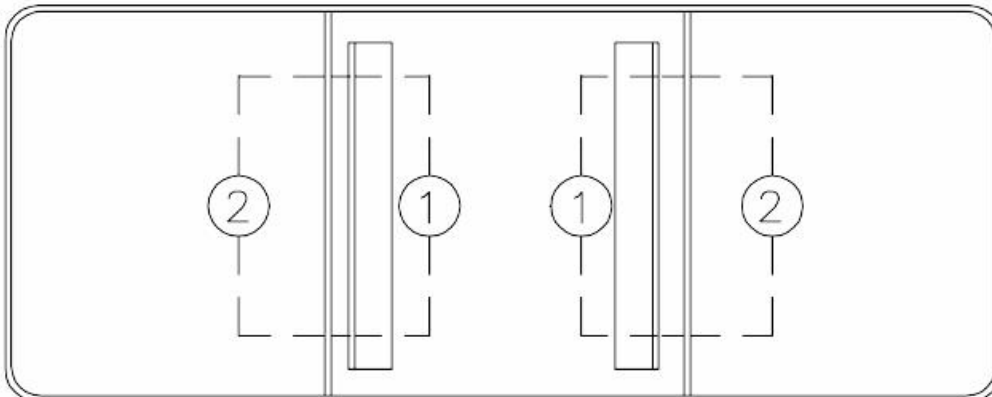

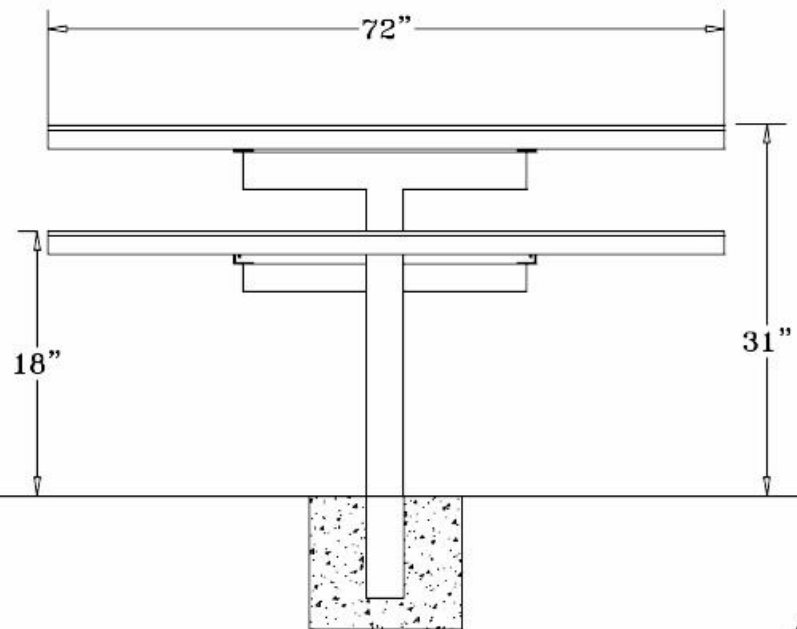
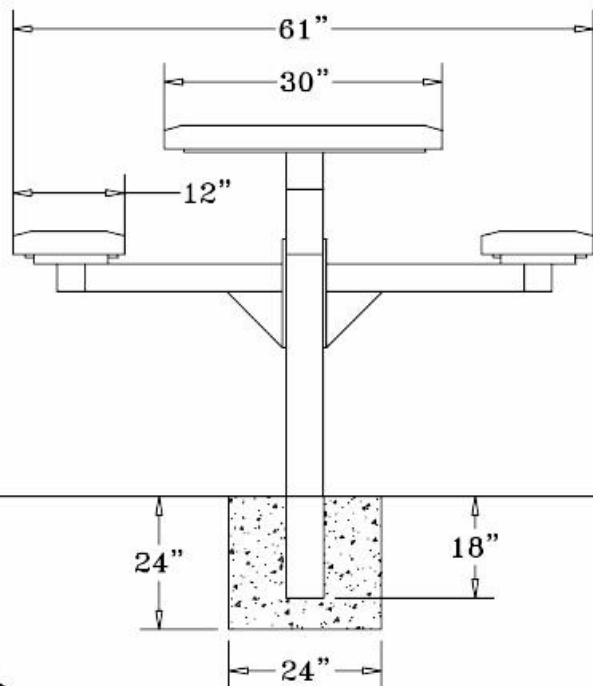

## SPECIFICATIONS

72" X 30" POLY VINYL EXPANDED METAL TABLE TOP WITH TWO ATTACHED 72" X 12" SEATS. THE FRAME IS A 4" SQUARE INGROUND MOUNT SINGLE PEDESTAL.

COATED WITH A 1/8" TO 1/4" THICK PLASTISOL ULTRAVIOLET STABILIZED VINYL COATING FUSED AND BAKED TO A 90% GLOSS.

TABLE HEIGHT 31" APPROXIMATELY. SEAT HEIGHT IS 18" APPROXIMATELY. TOTAL OVERALL DIMENSIONS ARE 72" X 61".

TOP AND SEATS ARE MADE FROM 10GA 3/8" X 9/16" PUNCHED STEEL. ALL CENTER BRACES ARE MADE FROM 1 1/2" X 1/4" FLAT STEEL.

FRAME IS A SINGLE 4" X 4" PEDESTAL MOUNTED TO THE CENTER OF THE TABLE TOP EXTENDING 48" UNDER TOP TO ALLOW FOR 18" OF INGROUND MOUNTING. EXTENDING OUT FROM THE 4" SQUARE TUBING ARE TWO 3" TUBING ARMS THAT THE SEATS ARE MOUNTED TO. COATED WITH A BAKED ON POLYESTER POWDER COAT FINISH.

ALL HARDWARE IS NON-CORROSIVE. WEIGHT FOR THE T6INNVPEDS IS 311 LBS.

## MAINTENANCE

To maintain luster it is recommended to wash, rinse, and dry the units after prolonged use. Check for loose bolts and nuts and tighten as needed. Contact the factory for genuine Webcoat part replacements if needed.