

# BIG TOP

MOLDED PLASTIC TOP  
FOR 55 GALLON TRASH RECEPTACLES

## **FURNITURE LEISURE INC**

OUR LIST OF WEB STORES

[www.FurnitureLeisure.com](http://www.FurnitureLeisure.com)    [www.PoolFurnitureSupply.com](http://www.PoolFurnitureSupply.com)  
[www.PicnicFurniture.com](http://www.PicnicFurniture.com)    [www.PicnicTableSupplier.com](http://www.PicnicTableSupplier.com)  
[www.ParkTables.com](http://www.ParkTables.com)    [www.UBrace.com](http://www.UBrace.com)

**1.800.213.2401**

Please take the time to locate and identify each part. Assemble the units on a smooth flat surface. It is also helpful to lay the tops and seats on cardboard or a drop cloth to prevent scratching of the surface during assembly. All parts have been pre-cut and pre-drilled for ease of assembly. All holes are slotted to allow for easy assembly and for final levelling of tops and seats to frames. Fully assemble all parts without totally tightening nuts and bolts. After all assembled go back and retighten nuts to bolts. **DO NOT OVER TIGHTEN NUTS TO BOLTS.** Over tightened nuts can crack the plastisol coating. All the necessary quantities of parts required are listed in this assembly instructions.

**DO NOT BEGIN ASSEMBLY UNTIL YOU HAVE READ THESE INSTRUCTIONS AND ARE FAMILIAR WITH THE PARTS.**



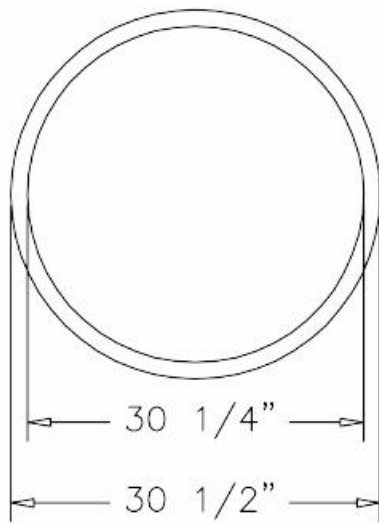

BOTTOM VIEW A-A

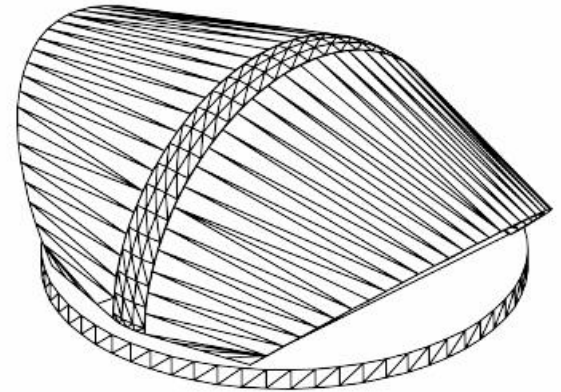

BIG TOP

## SPECIFICATIONS

MOLDED STRUCTURAL PLASTIC TOP FOR 55 GALLON TRASH RECEPTACLES.

MOLDED STRUCTURAL PLASTIC BIG TOPS SECURED WITH CHAIN ASSEMBLY MOUNTED BY ONE WAY SCREWS. BIG TOPS ARE GUARANTEED NOT TO DENT, RUST, CRACK OR PEEL.

ALL HARDWARE IS NON-CORROSIVE.  
WEIGHT FOR THE BIG TOP IS 35 LB.

## MAINTENANCE

To maintain luster it is recommended to wash, rinse, and dry the units after prolonged use. Check for loose bolts and nuts and tighten as needed. Contact the factory for genuine Webcoat part replacements if needed.