

ASSEMBLY AND MOUNTING INSTRUCTIONS – FORESITE DESIGNS  
8FOOT BENCH, PARK AVENUE DESIGN 400201

PAGE 1

## ASSEMBLY INSTRUCTIONS: BENCH 8 FOOT LENGTH 400201

1. Unpack and lay out pieces to assemble. Verify that the parts, quantity, and dimensions match those on the enclosed bill of material.
2. Begin by loosely assembling the bench end castings to the “back” support tube. See diagram 1.
3. Lay one 100029 end casting “back” side down and attach the “back” support tube 100034. Place the support tube into the “back” receiving hole of the casting and fasten with a 1/2 x 1 1/2 cap screw through a plastic spacer, through the casting, and into the threaded end of the support tube. See diagram 1. Hand snug the cap screw – do not tighten.
4. Lay the second 100029 end casting “back” side down and attach the “back” support tube 100034 following the same procedure as step 3.
5. Place the center support 100031 casting(s) at the proper location(s) on the “back” support tube. Rest support against the tubing. Reference from inside edge of one end casting to inside edge of support casting.
6. 8 foot bench is made of two sections. Section center support at 21 1/2 inches to edge of support. Put one section together at a time.
7. Place a bull nose board (best side facing you) nose down, into the lower pocket of one end casting and then into the lower pocket of the other end casting. Make certain that the support casting(s) behind the board and the radius portion of casting(s) is on the tubing. May need to spread the end castings outward at upper ends in order to get board in between the end casting flanges. This can be accomplished by loosening the cap screws a little. See diagram 2.
8. Continue to place boards into one pocket of an end casting and then into the other pocket in the order shown until last board for seat is in place. Keep best side facing out. Keep boards in front of the support casting(s). Make sure that boards center between the lugs on the support casting(s)
9. Install the “front” support tube 100034 between the two end castings seating the tubing in the radius portion of the support casting(s) and fasten with a 1/2 x 1 1/2 cap screw through a plastic spacer, through the casting, and into the threaded ends of the support tube.
10. Hand snug all cap screws to square up the frame made by the tubing and end castings.
11. Go around to the back and line up the support castings so they are vertical (parallel with end casting) and properly dimensioned.
12. From the back side drill a 5/32 pilot hole approximately 1/2 inch deep and install a 1/4 x 1 screw into the “seat” boards at each slotted hole in the support casting(s). See diagram 2.
13. Remove the cap screws from “right side facing” end of the bench assembly. Take care not to dislodge the end casting from the boards.
14. Take remaining support tubes 10034 and install 1/2 x 3 1/2 inch threaded rod into the threaded block of the free end of each tube. Turn in until rod length is 2 1/2 inch extended from threaded block. Press locking device over end of threaded rod and seat against welded block inside tube. Rotate rod until locking device is tight. See detail A. See diagram 3
15. Thread one support tube with rod into the “back” receiving hole of the “loose” end casting. Rotate the tube by hand to thread rod into threaded block of the opposite tube. Rotate until the tube is snug against the casting but not tight. Start the remaining tube in the “front” receiving hole but leave it looser than the “back” tube. See diagram 3.
16. Lay the third 100029 end casting “back” side down and attach the “back” support tube 100034. Place the support tubes into the “back” receiving hole of the casting and fasten with a 1/2 x 1 1/2 cap screw through a plastic spacer, through the casting, and into the threaded end of the support tube. Hand snug the cap screw – do not tighten. Repeat for the “front” hole but leave this cap screw looser. See diagram 3.
17. Center the support casting at 21.5 inches on the support tubes.
18. Place a bull nose board (best side facing you) nose down, into the lower pocket of one end casting and then into the lower pocket of the other end casting. Make certain that the support casting(s) behind the board and the radius portion of casting(s) is on the tubing. May need to spread the end castings outward at upper ends in order to get board in between the end casting flanges. This can be accomplished by loosening the cap screws a little. See diagram 4.

ASSEMBLY AND MOUNTING INSTRUCTIONS – FORESITE DESIGNS  
8FOOT BENCH, PARK AVENUE DESIGN 400201

PAGE 2

19. Continue to place boards into one pocket of an end casting and then into the other pocket in the order shown until last board for seat is in place. Keep best side facing out. Keep boards in front of the support casting. Make sure that boards center between the lugs on the support casting.
20. Rotate the tubing with threaded rod to take up loose slack between the tube and end casting. May need to hold the opposite tube if it wants to rotate. Tighten just enough so there is very little play between the casting and the tubes.
21. Hand snug all outside end cap screws to square up the frame made by the tubing and end castings.
22. Go around to the back and line up the support castings so they are vertical (parallel with end casting) and properly dimensioned.
23. From the back side drill a 5/32 pilot hole approximately 1/2 inch deep and install a 1/4 x 1 screw into the "seat" boards at each slotted hole in the support casting(s).
24. Set the bench upright to finish the assembly. Begin with one section of the back and place boards into the back pockets. Follow steps 25-28. When complete do the next section in same manner. See diagram 4
25. Place a bull nose board (best side facing out) nose down, into the lower pocket of one end casting and then into the lower pocket of the other end casting. Make certain that the support casting is behind the board. May need to spread the end castings outward at upper ends in order to get board in between the end casting flanges. This is accomplished by loosening the cap screws and tubing slightly. See diagram 4.
26. Continue to place boards into one pocket of an end casting and then into the other pocket in the order shown until last board for back is in place. Keep best side facing out. Keep boards in front of the support casting(s). Make sure that boards center between the lugs on the support casting(s).
27. Tighten the four cap screws to secure the end castings to the support tubes. Make certain that the alignment between the end castings is plumb when tightening so bench doesn't rock.
28. From the back side drill a 5/32 pilot hole approximately 1/2 inch deep and install a 1/4 x 1 screw into the "back" boards at each slotted hole in the support casting.
29. The bench is now ready for mounting. Mounting is shown in diagram 5.

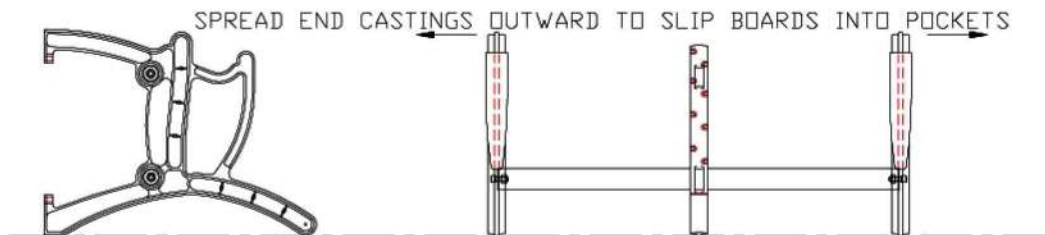
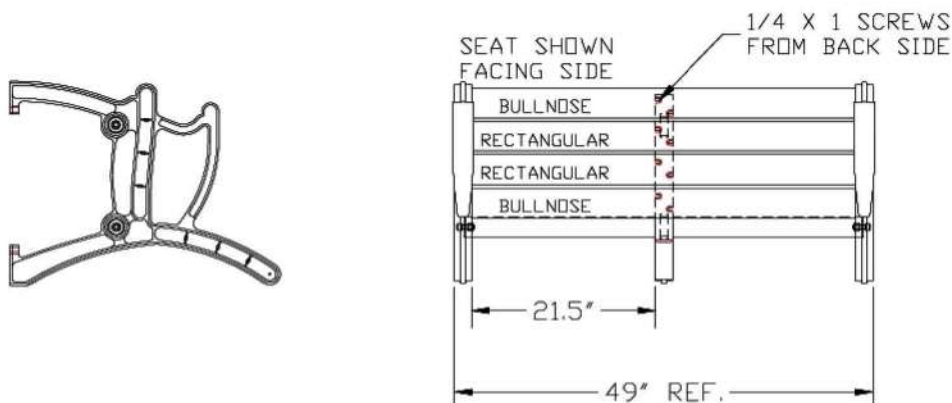
**DIAGRAM 1: END CASTING AND SUPPORT TUBE ASSEMBLY****DIAGRAM 2: PLACING AND FASTENING "SEAT" BOARDS IN PLACE SECTION 1**

DIAGRAM 3: PLACING AND FASTENING “SEAT” BOARDS IN PLACE SECTION TWO  
ATTACHING OTHER SUPPORT TUBES AND CASTINGS

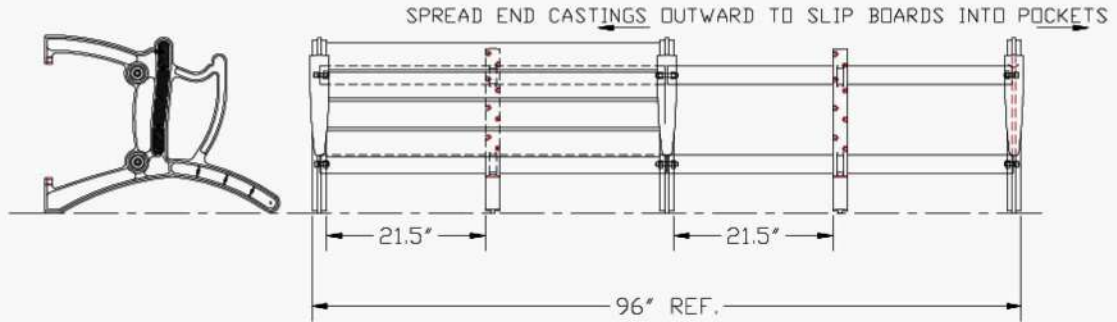
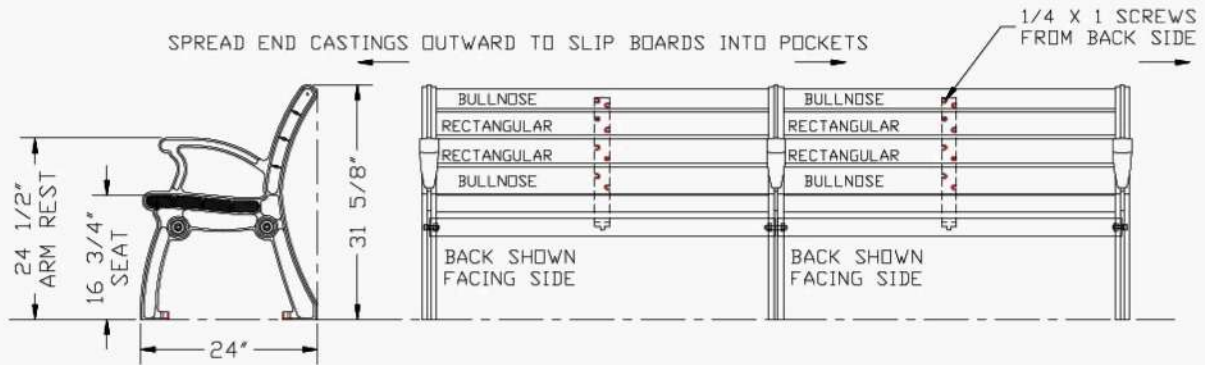
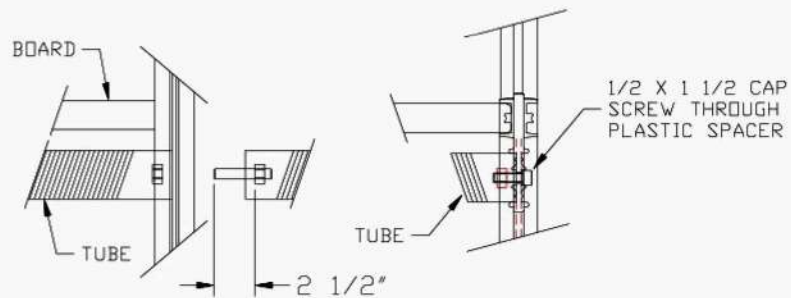


DIAGRAM 4: PLACING AND FASTENING “BACK BOARDS IN PLACE BOTH SECTIONS  
ONE SECTION AT A TIME



DETAIL A: CAP SCREWS AND THREADED ROD ATTACHMENT.



ASSEMBLY AND MOUNTING INSTRUCTIONS – FORESITE DESIGNS  
8FOOT BENCH, PARK AVENUE DESIGN 400201  
PAGE 4

DIAGRAM 5: BENCH 8 FOOT LENGTH 400201, SURFACE MOUNTING

