

ASSEMBLY AND MOUNTING INSTRUCTIONS – FORESITE DESIGNS
5 FOOT SEAT, PARK AVENUE DESIGN 300001

PAGE 1

ASSEMBLY INSTRUCTIONS: SEAT 5 FOOT LENGTH 300001

1. Unpack and lay out pieces to assemble. Verify that the parts, quantity, and dimensions match those on the enclosed bill of material.
2. Begin by setting up seat boards with two rectangular boards in center and one bull nose board on each side with curved section facing out. Set boards on flat work surface with best surface down as this will be the top of the seat. See diagram 1.
3. Use a square to line up all the board ends so they are parallel. Then locate the center support casting 100036 flat side down on the boards, at a distance of 18 1/8 inches from end of the boards to the edge of casting plate. Make certain the spacing lugs of the support casting all fit between the edges of the boards. Make certain there is a 3/8 inch gap between all boards.
4. Drill 5/32 diameter pilot hole (eight places) into the board and install eight 1/4 x 1 screws into the board. (use holes in casting as a drill guide)
5. Locate the second center support casting 100036 at a distance of 37 3/8 inches from end of boards to edge of casting plate. Make certain the spacing lugs of the support casting all fit between the edges of the boards.
6. Drill 5/32 diameter pilot hole (eight places) into the board and install eight 1/4 x 1 screws into the board. (use holes in casting as a drill guide)
7. Locate one seat end casting 100033 at the ends of the boards, making sure that the spacing lugs of the casting all fit between the board edges. Press casting firmly against board ends to seat the casting. See diagram 2. Use a hand square to line up board on plate.
8. Lay the support tubes 100035 (two items) onto the center support and gently seat the ends of each tube into the receiving hole on the end casting. See diagram 2.
9. Install two 1/2 x 1 1/2 cap head screws through spacers into the threaded end of the tube and tighten just enough to make sure tubing will stay in receiving hole of casting. See detail A.
10. Locate the other seat end casting 100033 at the other ends of the boards, making sure that the spacing lugs of the casting all fit between the board edges. Press casting firmly against board ends to seat the casting. See diagram 2.
11. Install two 1/2 x 1 1/2 cap head screws through spacers into the threaded end of the tube and tighten just enough to make sure tubing will stay in receiving hole of casting. See detail A.
12. Set the seat upright on a flat level surface and tighten the four cap screws securely seating the tubing firmly in the receiving holes of the castings.
13. Mount the seat using 4 concrete anchors at dimensions shown in diagram 3

DIAGRAM 1: SEAT 5 FOOT LENGTH 300001
ATTACHING SUPPORT CASTINGS (TWO)

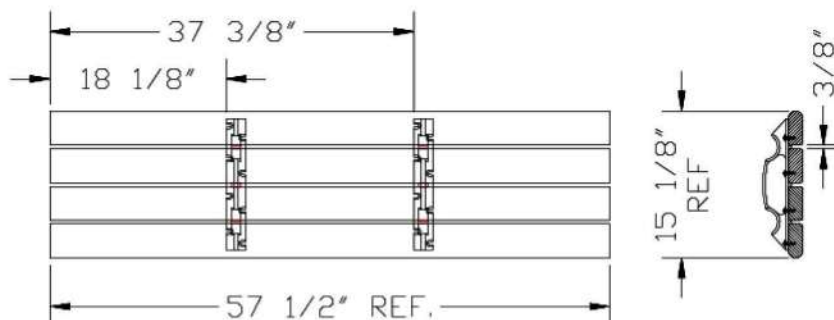

ASSEMBLY AND MOUNTING INSTRUCTIONS – FORESITE DESIGNS
5 FOOT SEAT, PARK AVENUE DESIGN 300001

PAGE 2

DIAGRAM 2: SEAT 5 FOOT LENGTH 300001 SHOWN
ATTACHING SEAT END CASTINGS AND TUBES

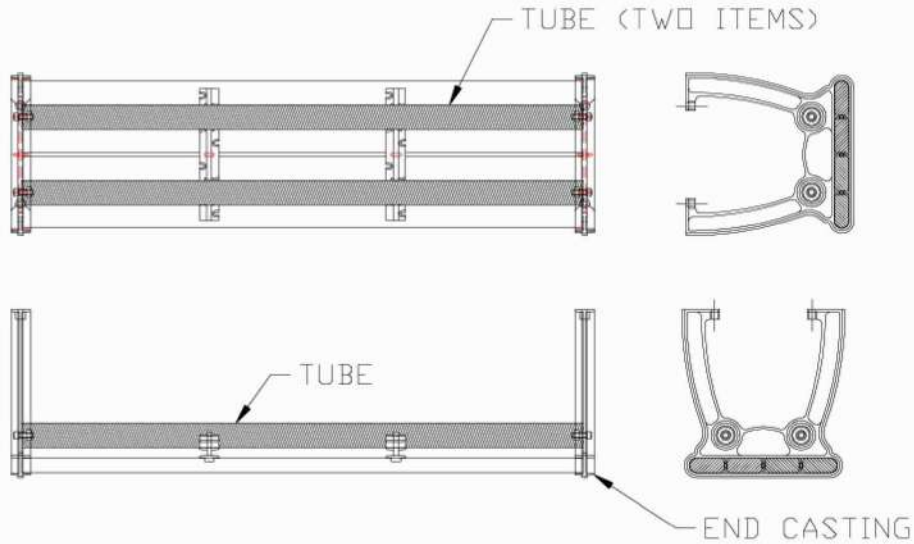

DETAIL A: ATTACHING END CASTINGS AND FASTENING TUBES

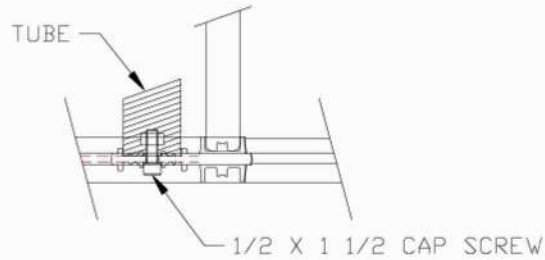

DIAGRAM 3: SEAT 5 FOOT LENGTH 300001, SURFACE MOUNTING

