

ASSEMBLY AND MOUNTING INSTRUCTIONS – FORESITE DESIGNS
 8 FOOT BENCH WITH ARMS, PARK SCAPE DESIGN 150201, 150202, AND 150203
 PAGE 2

17. Make marks on each plate at a distance of $2\frac{7}{8}$, $7\frac{1}{8}$ inches from the end of the plate. Diagram 2
18. Locate one bull nose board on the weldments at a distance of $3\frac{1}{4}$ inches from end of the board to edge of weldment plate with flat edge of board on the $7\frac{1}{8}$ inch marks. Make certain curved edge is facing bend in plate. Clamp board in place. See diagram 3. **IMPORTANT: Make sure that the distance between the two bull nose boards where seat meets the back measures 4 inches or less. Adjust the board on the back to meet 4 inch maximum dimension.**
19. Drill $\frac{5}{32}$ diameter pilot hole (six places) into the board and install six $\frac{1}{4}$ x 2 screws into the board. (use third line of 2 holes in metal plate of weldment as a drill guide)
20. Set one rectangular board at a distance of $3\frac{1}{4}$ inches from plate side edge to end of board with flat edge of board on the $2\frac{7}{8}$ inch mark. Suggest placing a $\frac{3}{4}$ inch thick spacer between the bull nose and rectangular board at each end to maintain $\frac{3}{4}$ inch gap. See diagram 3.
21. Drill $\frac{5}{32}$ diameter pilot hole (six places) into the board and install six $\frac{1}{4}$ x 2 screws into the board. (use third line of 2 holes in metal plate of weldments as a drill guide) Diagram 3.
22. Locate second bull nose board at a distance of $3\frac{1}{4}$ inches from plate side edge to end of board with a gap distance of $\frac{3}{4}$ inches between bull nose and rectangular boards at both ends. Suggest placing a $\frac{3}{4}$ inch thick spacer between the bull nose and rectangular board at each end to maintain $\frac{3}{4}$ inch gap. Clamp board in place. See diagram3.
23. Check square ness of boards with plates before tightening all screws.

DIAGRAM 2: BENCH WITH ARMS 8 FOOT 150201 SHOWN (ATTACHING SEAT BOARDS)

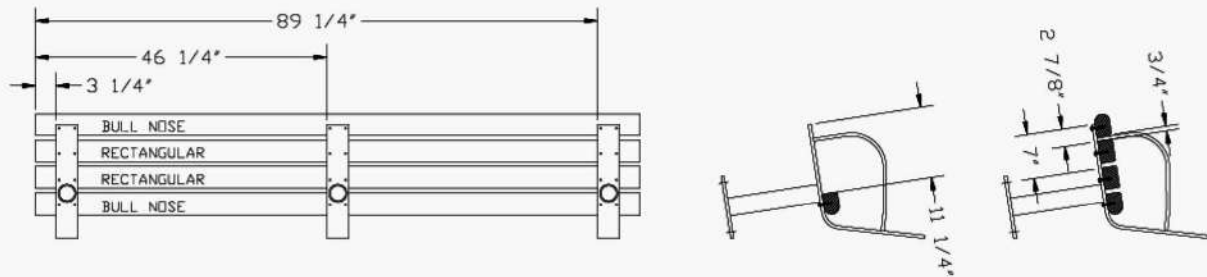
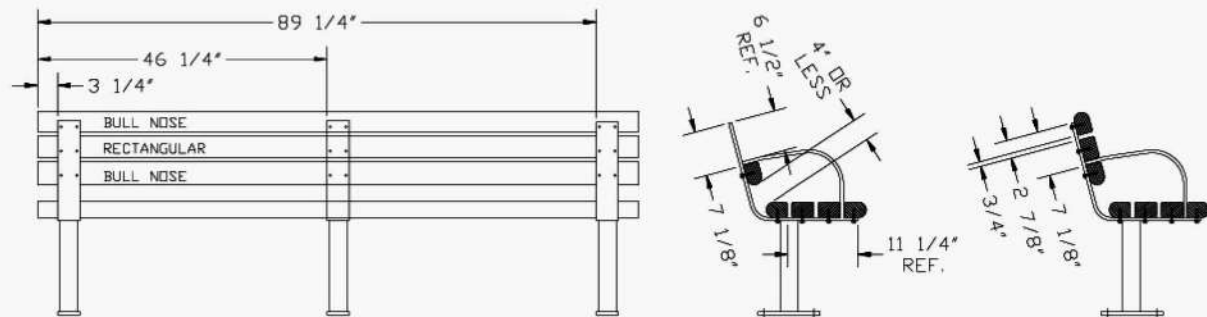

DIAGRAM 3: BENCH WITH ARMS 8 FOOT 150201 SHOWN (ATTACHING BACK BOARDS)



ASSEMBLY AND MOUNTING INSTRUCTIONS – FORESITE DESIGNS
 8 FOOT BENCH WITH ARMS, PARK SCAPE DESIGN 150201, 150202, AND 150203
 PAGE 3

MOUNTING INSTRUCTIONS: BENCH WITH ARMS 8 FOOT LENGTH 150201, 150202, and 150203

1. Surface mount bench 150201 mounts with six ½ inch anchors into concrete surface at dimensions as shown on diagram 3.
2. Embedded mount bench 150202 mounts by setting in filled holes at dimensions as shown on diagram 3.
3. Portable bench 150203 will rest on any flat, even surface-no mounting required

DIAGRAM 4: BENCH WITH ARMS 8 FOOT LENGTH, SHOWN ARE
 SURFACE 150201 CONCRETE ANCHORS 6 PLACES
 EMBEDDED 150202 HOLES 3 PLACES
 PORTABLE 150203 NO MOUNTING

SURFACE 150201

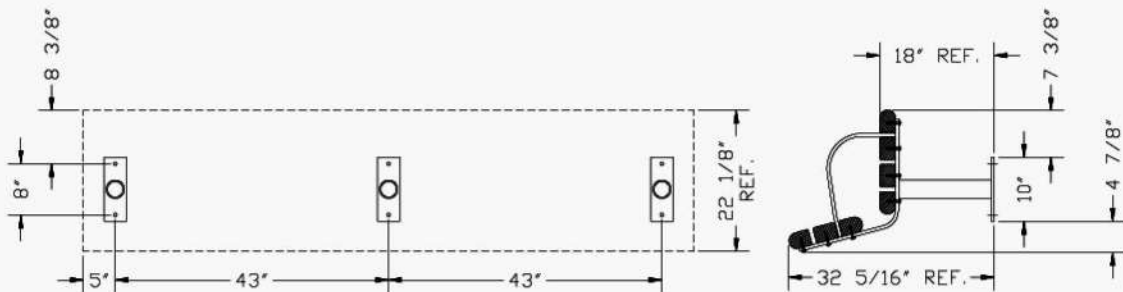

EMBEDDED 150202

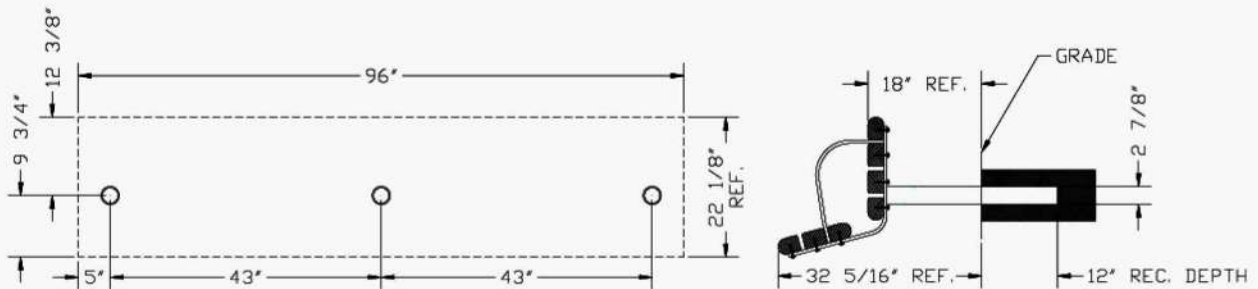

PORTABLE 150203

