

ASSEMBLY AND MOUNTING INSTRUCTIONS – FORESITE DESIGNS
6 FOOT BENCH, PARKSCAPE DESIGN 140101, 140102, AND 140103

PAGE 1

ASSEMBLY INSTRUCTIONS: BENCH 6 FOOT LENGTH 140101, 140102, and 140103

1. Unpack and lay out pieces to assemble. Verify that the parts, quantity and dimensions match those on the enclosed bill of material.
2. Begin by setting up two support frame weldments on a smooth, level surface roughly 62 inches apart on centers laying them on their back with “seat” in a “vertical” direction. Center the third weldment between them. See diagram 1.
3. Make marks on each plate at a distance of 2 7/8, 7, and 11 1/4 inches from the end of the plate. Diagram 2.
4. Locate one bull nose board on the weldment at a distance of 3 1/4 inches from end of the board to edge of weldment plate and flat edge on the 11 1/4 inch mark. Make certain curved edge is facing bend in plate.
5. Clamp board to weldment and locate the second weldment at distance of 34 1/4 inches from end of board and the board flat edge on the 11 1/4 inch mark. Clamp board to weldment. Use a hand square to align plates perpendicular to board. See diagram 2.
6. Locate the third weldment at distance of 65 1/4 inches from end of board and the board flat edge on the 11 1/4 inch mark. Clamp weldment to board. Use a hand square to align plates perpendicular to board. See diagram 2.
7. Drill 5/32 diameter pilot hole (six places) into the board and install six 1/4 x 2 screws into the board. (use fourth line of 2 holes in metal plate of weldments as a drill guide)
8. Set one rectangular board at a distance of 3 1/4 inches from plate side edge to end of board with flat edge on the 7 inch marks. Suggest placing a 3/4 inch thick spacer between the bull nose and rectangular board at each end to maintain 3/4 inch gap. Clamp board in place. See diagram 2.
9. Drill 5/32 diameter pilot hole (six places) into the board and install six 1/4 x 2 screws into the board. (use third line of 2 holes in metal plate of weldment as a drill guide)
10. Set the second rectangular board at a distance of 3 1/4 inches from plate side edge to end of board with flat edge of board on 2 7/8 inch mark. Suggest placing a 3/4 inch thick spacer between the two rectangular boards at each end to maintain 3/4 inch gap. See diagram 2.
11. Drill 5/32 diameter pilot hole (six places) into the board and install six 1/4 x 2 screws through washers into the board. (use second line of 2 holes in metal plate of weldments as a drill guide)
12. Locate second bull nose board at a distance of 3 1/4 inches from plate side edge to end of board and at a gap distance of 3/4 inch between bull nose and rectangular board. Suggest placing a 3/4 inch thick spacer between the bull nose and rectangular board at each end to maintain 3/4 inch gap. See diagram 2.
13. Drill 5/32 diameter pilot hole (six places) into the board and install six 1/4 x 2 screws through washers into the board. (use first line of 2 holes in metal plate of weldments as a drill guide)
14. Check square ness of boards with plates with hand square before tightening screws.
15. Set the bench upright to fasten the boards on the back. See diagram 3.

DIAGRAM 1: BENCH 6 FOOT LENGTH SURFACE 140101, 140102 & 140103 SHOWN

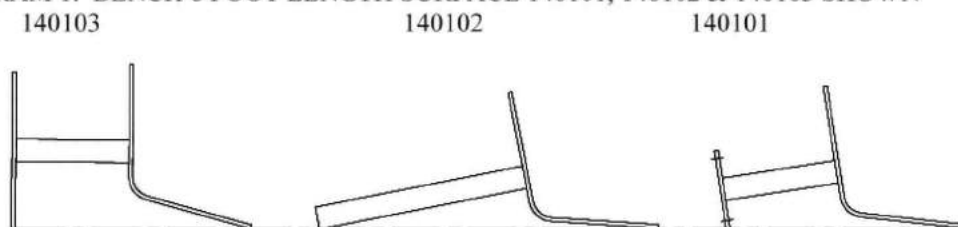

FURNITURE LEISURE INC

1.800.213.2401

www.FurnitureLeisure.com
www.PicnicFurniture.com
www.ParkTables.com

www.PoolFurnitureSupply.com
www.PicnicTableSupplier.com
www.UBrace.com

ASSEMBLY AND MOUNTING INSTRUCTIONS – FORESITE DESIGNS
6 FOOT BENCH, PARKSCAPE DESIGN 140101, 140102, AND 140103

PAGE 2

16. Make marks on each plate at a distance of $2\frac{7}{8}$, $7\frac{1}{8}$ inches from the end of the plate. Diagram 2
17. Locate one bull nose board on the weldments at a distance of $3\frac{1}{4}$ inches from end of the board to edge of weldment plate with flat edge of board on the $7\frac{1}{8}$ inch marks. Make certain curved edge is facing bend in plate. Clamp board in place. See diagram 3. **IMPORTANT: Make sure that the distance between the two bull nose boards where seat meets the back measures 4 inches or less. Adjust the board on the back to meet 4 inch maximum dimension.**
18. Drill $\frac{5}{32}$ diameter pilot hole (six places) into the board and install six $\frac{1}{4}$ x 2 screws into the board. (use third line of 2 holes in metal plate of weldments as a drill guide) Diagram 3.
19. Set one rectangular board at a distance of $3\frac{1}{4}$ inches from plate side edge to end of board with flat edge of board on the $2\frac{7}{8}$ inch mark. Clamp board in place. Suggest placing a $\frac{3}{4}$ inch thick spacer between the bull nose and rectangular board at each end to maintain $\frac{3}{4}$ inch gap. See diagram 3.
20. Drill $\frac{5}{32}$ diameter pilot hole (six places) into the board and install six $\frac{1}{4}$ x 2 screws into the board. (use second line of 2 holes in metal plate of weldments as a drill guide) Diagram 3.
21. Locate second bull nose board at a distance of $3\frac{1}{4}$ inches from plate side edge to end of board with a gap distance of $\frac{3}{4}$ inches between bull nose and rectangular boards at both ends. Suggest placing a $\frac{3}{4}$ inch thick spacer between the bull nose and rectangular board at each end to maintain $\frac{3}{4}$ inch gap. Clamp board in place. See diagram3.
22. Drill $\frac{5}{32}$ diameter pilot hole (four places) into the board and install four $\frac{1}{4}$ x 2 screws into the board. (use first line of 2 holes in metal plate of weldments as a drill guide) Diagram 3.
23. Check square ness of boards with plates before tightening all screws.

DIAGRAM 2: BENCH 6 FOOT LENGTH 140101 SHOWN (ATTACHING SEAT BOARDS)

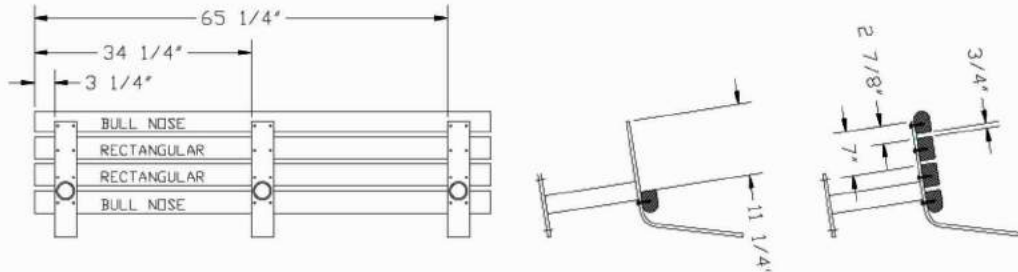
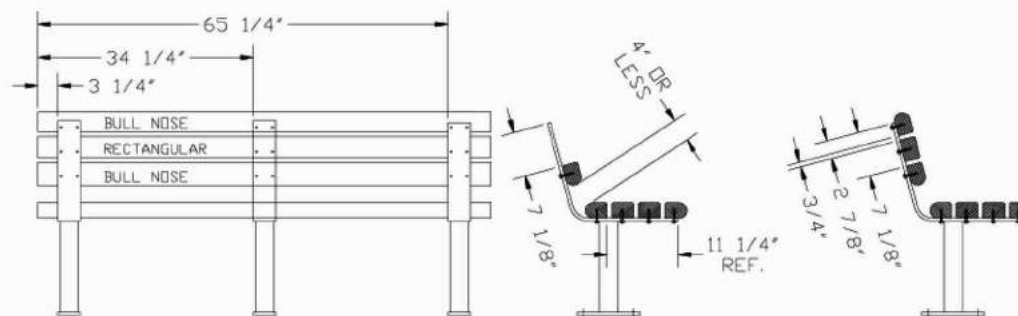

DIAGRAM 3: BENCH 6 FOOT LENGTH 140101 SHOWN (ATTACHING BACK BOARDS)



ASSEMBLY AND MOUNTING INSTRUCTIONS – FORESITE DESIGNS
 6 FOOT BENCH, PARKSCAPE DESIGN 140101, 140102, AND 140103
 PAGE 3

MOUNTING INSTRUCTIONS: BENCH 6 FOOT LENGTH 140101, 140102, and 140103

1. Surface mount bench 140101 mounts with ½ inch anchors into concrete surface at dimensions as shown on diagram 3.
2. Embedded mount bench 140102 mounts by setting in filled holes at dimensions as shown on diagram 3.
3. Portable bench 140103 will rest on any flat, even surface-no mounting required

DIAGRAM 4: BENCH 6 FOOT LENGTH, SHOWN ARE
 SURFACE 140101 CONCRETE ANCHORS 4 PLACES
 EMBEDDED 140102 HOLES 2 PLACES
 PORTABLE 140103 NO MOUNTING

SURFACE 140101

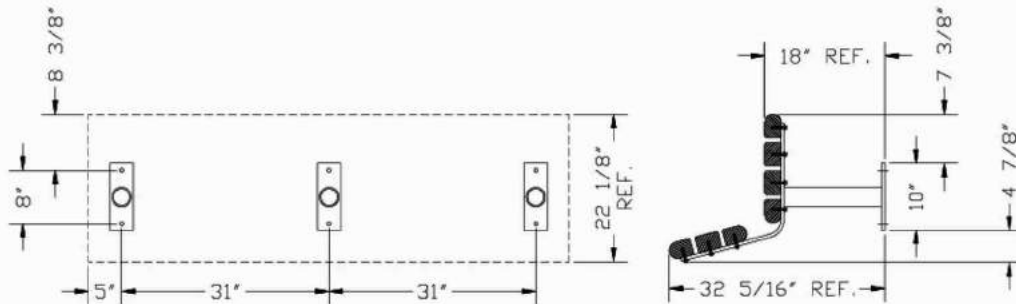

EMBEDDED 140102

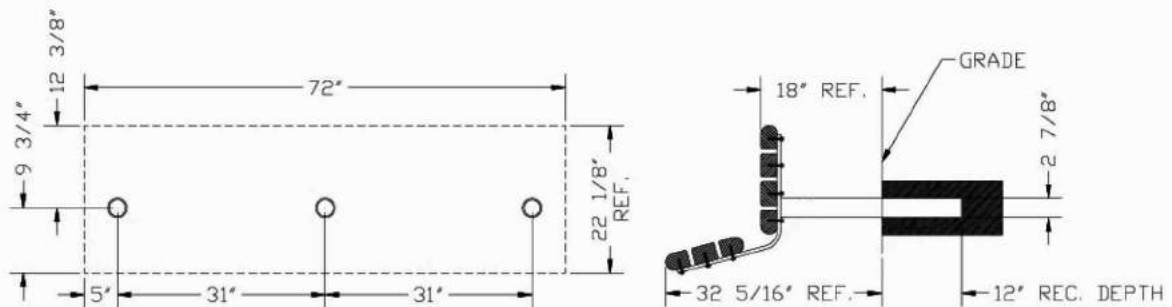

PORTABLE 140103

