

B6WBMODERNPSM

6' MODERN STYLE
BENCH WITH BACK
SURFACE MOUNT DESIGN
WITH SURFACE MOUNT COVERS

FURNITURE LEISURE INC

OUR LIST OF WEB STORES

www.FurnitureLeisure.com
www.PicnicFurniture.com
www.ParkTables.com

www.PoolFurnitureSupply.com
www.PicnicTableSupplier.com
www.UBrace.com

1.800.213.2401



Please take the time to locate and identify each part. Assemble the units on a smooth flat surface. It is also helpful to lay the tops and seats on cardboard or a drop cloth to prevent scratching of the surface during assembly. All parts have been pre-cut and pre-drilled for ease of assembly. All holes are slotted to allow for easy assembly and for final levelling of tops and seats to frames. Fully assemble all parts without totally tightening nuts and bolts. After all assembled go back and retighten nuts to bolts. DO NOT OVER TIGHTEN NUTS TO BOLTS. Over tightened nuts can crack the plastisol coating. All the necessary quantities of parts required are listed in this assembly instructions.

DO NOT BEGIN ASSEMBLY UNTIL YOU HAVE READ THESE INSTRUCTIONS AND ARE FAMILIAR WITH THE PARTS.

PARTS IDENTIFICATION

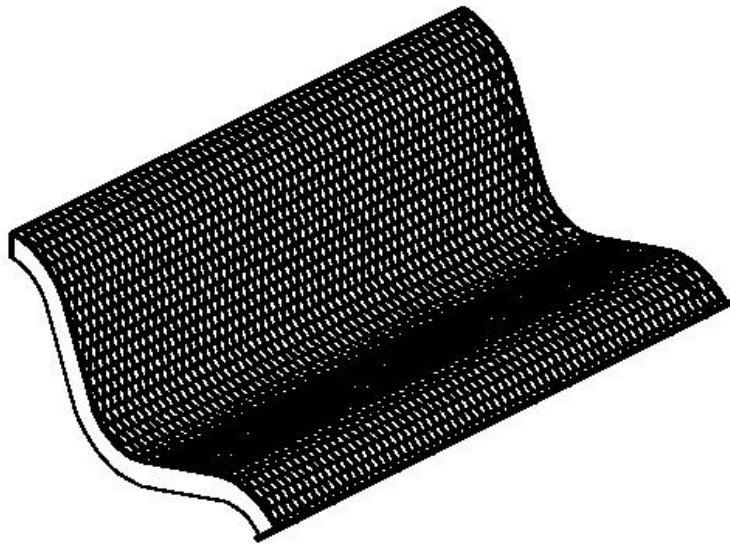

(A) 6' MODERN SEAT WITH BACK



(B) BENCH FRAME

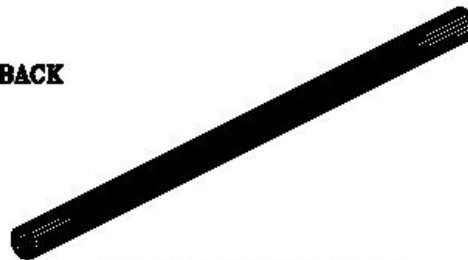

(C) CONNECTING PIPE

PARTS LIST

ITEM	PART#	DESCRIPTION	QTY.
A	SCWEMODERN	6' MODERN SEAT W/BACK	1
B	FEWEMODERNP	MODERN BENCH FRAME	2
C	F6CPIPE	CONNECTING PIPE	2

ITEM	HARDWARE DESCRIPTION	QTY.
HW1	5/16" X 18 NYL LOCKNUTS	4
HW2	5/16" X 18GA CAP BOLTS	4
HW3	5/16" FLAT WASHERS	8
HW4	BOLT GUARDS	4

ASSEMBLY TOOLS REQUIRED
2- 1/2" WRENCHES

HARDWARE IDENTIFICATION



(HW1) 5/16" X 18
NYL LOCKNUTS



(HW2) 5/16" X 18
GAUGE CAP BOLTS



(HW3) 5/16"
FLAT WASHERS



(HW4) BOLT
GUARDS

ASSEMBLY PROCEDURES

STEP 1

SLIDE THE TWO 48 1/2" X 2 3/8" STRAIGHT TUBING OVER THE ROUND STUBS THAT ARE FACING EACH OTHER. THIS WILL SPREAD THE ENDS APART THE PROPER DISTANCE AND JOIN THE ENDS TOGETHER.

STEP 2

SET THE ONE PIECE SEAT INTO THE FRAME, WITH THE FRAME MOUNTING BRACKETS TO THE INSIDE OF THE SEAT.

STEP 3

MOUNT THE SEAT TO THE FRAME USING FOUR 5/16" BOLTS, EIGHT 5/16" FLAT WASHERS AND FOUR NYLOCK NUTS THROUGH THE SLOTTED HOLES IN THE UNDER SEAT SUPPORTS AND THROUGH THE SLOTTED HOLES ON THE FRAME SET SUPPORTS ON EACH END OF THE FRAME.

STEP 4

TIGHTEN ALL NUTS ON ALL BOLTS AND PLACE THE BOLT GUARDS ON ALL NUTS.
DO NOT OVER TIGHTEN THE NUTS AS THIS COULD CAUSE THE PLASTISOL COATING TO CRACK.

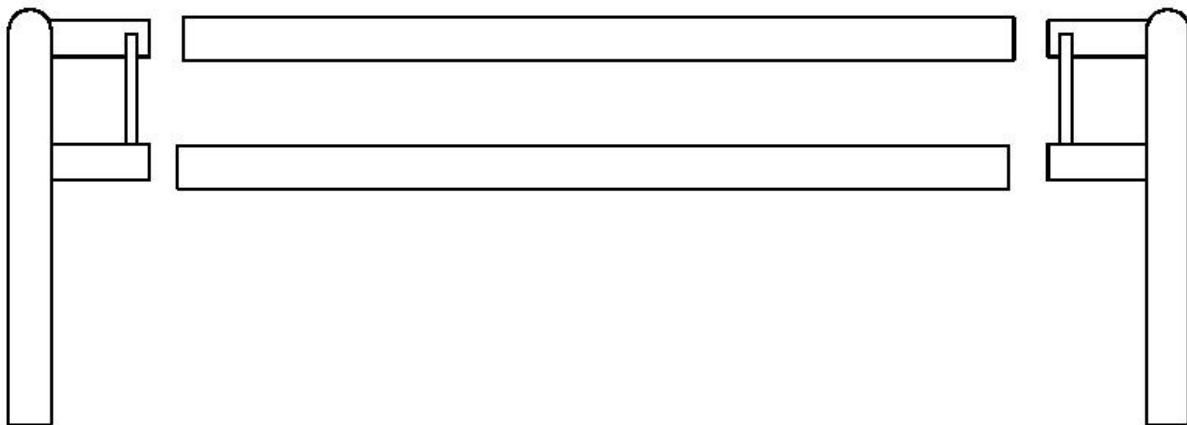

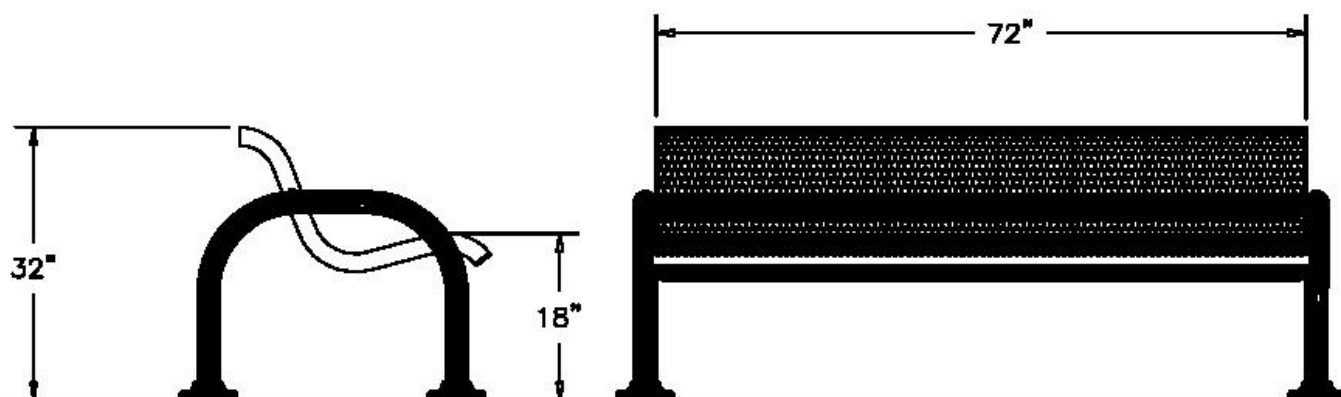

SPECIFICATIONS

6' POLY VINYL CURVED EXPANDED METAL MODERN BENCH WITH BACK. THE ONE PIECE DESIGN CREATES THE CONTEMPORARY LOOK WITH THE MAXIMUM OF STRENGTH. FRAME IS PORTABLE OR SURFACE MOUNT DESIGN.

COATED WITH A 1/8" TO 1/4" THICK PLASTISOL ULTRAVIOLET STABILIZED VINYL COATING FUSED AND BAKED TO A 90% GLOSS.

SEAT HEIGHT IS 18" APPROXIMATELY. BACK HEIGHT IS 32" APPROXIMATELY. TOTAL OVERALL DIMENSIONS ARE 72" X 32" APPROXIMATELY.

SEAT IS MADE FROM HEAVY DUTY 3/4" #9 EXPANDED METAL INSIDE A 3/16" FLAT STEEL FRAME.

UNDERSTRUCTURE IS MADE FROM HEAVY WALL TUBING IN A FOUR PIECE DESIGN, FABRICATED TO CREATE ARM RESTS ON EACH END. UNDER FRAME IS MADE OF 2 7/8" GALVANIZED TUBING THAT IS COATED WITH A BAKED ON DRY POLYESTER POWDER COAT FINISH.

ALL HARDWARE IS NON-CORROSIVE.

WEIGHT FOR THE B6WBMODERNISM IS 140 LBS.

MAINTENANCE

To maintain luster it is recommended to wash, rinse, and dry the units after prolonged use. Check for loose bolts and nuts and tighten as needed. Contact the factory for genuine Webcoat part replacements if needed.