

# B6WBULP

6' UNLIMITED STYLE  
BENCH WITH BACK  
PORTABLE DESIGN

## FURNITURE LEISURE INC

### OUR LIST OF WEB STORES

[www.FurnitureLeisure.com](http://www.FurnitureLeisure.com)

[www.PicnicFurniture.com](http://www.PicnicFurniture.com)

[www.ParkTables.com](http://www.ParkTables.com)

[www.PoolFurnitureSupply.com](http://www.PoolFurnitureSupply.com)

[www.PicnicTableSupplier.com](http://www.PicnicTableSupplier.com)

[www.UBrace.com](http://www.UBrace.com)

**1.800.213.2401**



Please take the time to locate and identify each part. Assemble the units on a smooth flat surface. It is also helpful to lay the tops and seats on cardboard or a drop cloth to prevent scratching of the surface during assembly. All parts have been pre-cut and pre-drilled for ease of assembly. All holes are slotted to allow for easy assembly and for final levelling of tops and seats to frames. Fully assemble all parts without totally tightening nuts and bolts. After all assembled go back and retighten nuts to bolts. DO NOT OVER TIGHTEN NUTS TO BOLTS. Over tightened nuts can crack the plastisol coating. All the necessary quantities of parts required are listed in this assembly instructions.

DO NOT BEGIN ASSEMBLY UNTIL YOU HAVE READ THESE INSTRUCTIONS AND ARE FAMILIAR WITH THE PARTS.

# PARTS IDENTIFICATION

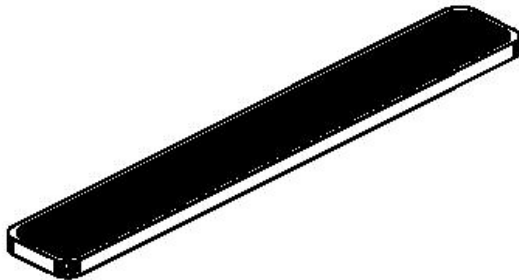

(A) 6' UL SEAT



(B) BENCH FRAME



(C) DIAGONAL

## PARTS LIST

ITEM	PART#	DESCRIPTION	QTY.
A	SCUL	6' UL SEAT	2
B	FEWEP	BENCH FRAME W/BACK	2
C	D6	DIAGONAL	2

ITEM	HARDWARE DESCRIPTION	QTY.
HW1	5/16" X 18 NYL LOCKNUTS	11
HW2	5/16" X 18GA CAP BOLTS	11
HW3	5/16" FLAT WASHERS	22
HW4	BOLT GUARDS	11

**ASSEMBLY TOOLS REQUIRED**  
2- 1/2" WRENCHES

## HARDWARE IDENTIFICATION



(HW1) 5/16" X 18  
NYL LOCKNUTS

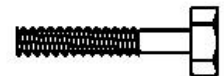

(HW2) 5/16" X 18  
GAUGE CAP BOLTS



(HW3) 5/16"  
FLAT WASHERS



(HW4) BOLT  
GUARDS

# ASSEMBLY PROCEDURES

## STEP 1

MOUNT THE FRAMES TO THE SEATS, THE FLATS ON THE FRAMES MUST BE BOLTED TO THE OUTSIDE OF THE BRACES ON THE SEAT. FASTEN BY MEANS OF FOUR 5/16" X 1 1/2" HEXBOLT, EIGHT 5/16" FLAT WASHERS, AND FOUR 5/16" NYLOCK NUTS.  
Hand tighten only at this time.

## STEP 2

MOUNT THE SEAT BACKS TO THE FRAMES, THE FLATS ON THE FRAMES MUST BE BOLTED TO THE OUTSIDE OF THE BRACES ON THE BACKS. FASTEN BY MEANS FOUR 5/16" X 1 1/2" HEXBOLT, EIGHT 5/16" FLAT WASHERS, AND FOUR 5/16" NYLOCK NUTS. Hand tighten only at this time.

## STEP 3

MOUNT THE SET OF DIAGONALS TO THE HOLES ON THE CENTER BRACES OF THE SEAT. MOUNT THE OTHER END OF THE DIAGONALS TO THE TAB ON EACH END OF THE FRAMES. THE DIAGONALS ARE FASTENED TOGETHER BY MEANS OF THREE 5/16" X 1 1/2" HEXBOLTS, SIX 5/16" FLAT WASHERS, AND THREE 5/16" NYLOCK NUTS.

## STEP 4

TIGHTEN ALL NUTS ON ALL BOLTS AND PLACE THE BOLT GUARDS ON ALL NUTS. **DO NOT OVER TIGHTEN THE NUTS AS THIS COULD CAUSE THE PLASTISOL COATING TO CRACK.**



ANGLE BOLTS TO INSIDE OF BRACE, FACING EACH OTHER.

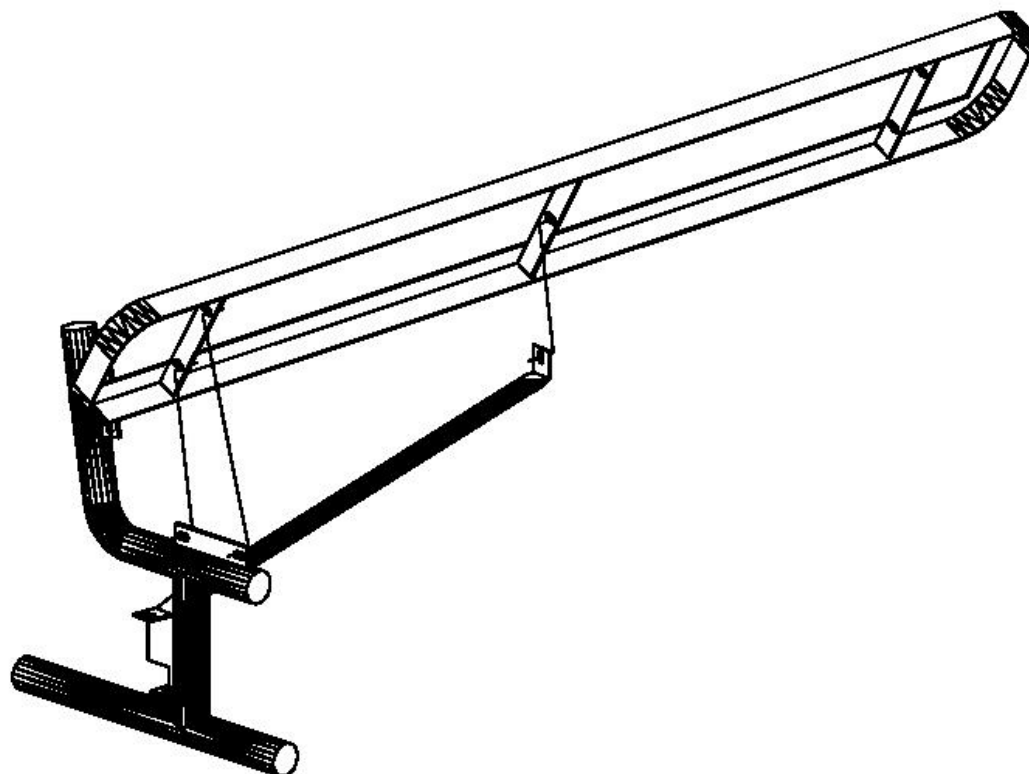

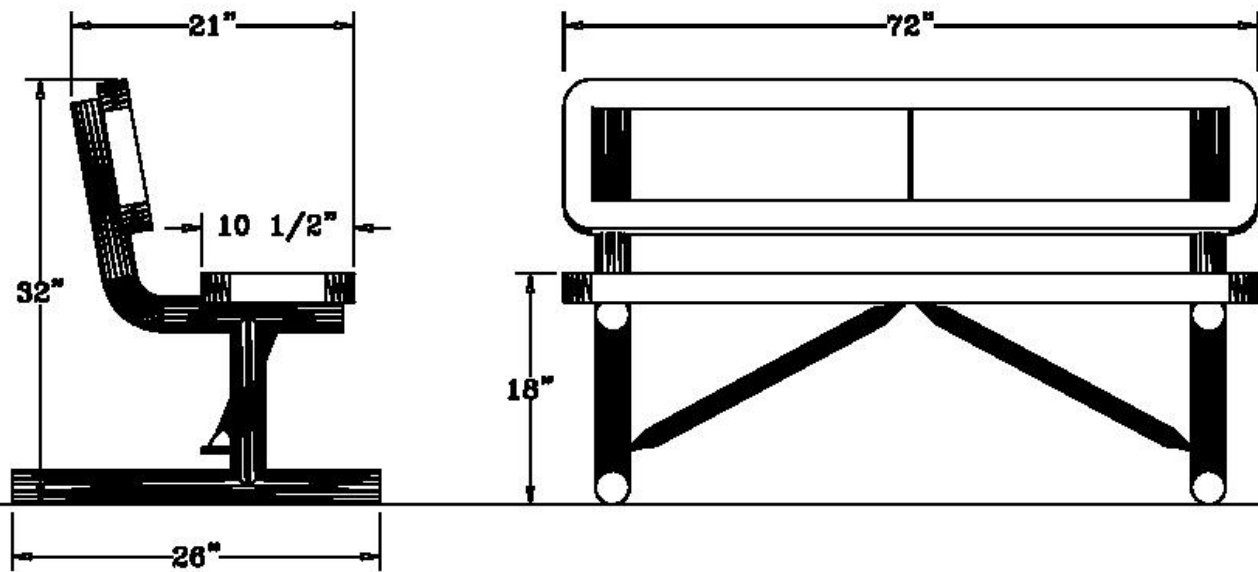

## SPECIFICATIONS

6' POLY VINYL EXPANDED METAL BENCH WITH BACK. ALL CORNERS ARE ROUNDED. FRAME IS PORTABLE DESIGN.

COATED WITH A 1/8" TO 1/4" THICK PLASTISOL ULTRAVIOLET STABILIZED VINYL COATING FUSED AND BAKED TO A 90% GLOSS.

SEAT HEIGHT IS 18" APPROXIMATELY, BENCH HEIGHT IS 32" APPROXIMATELY. TOTAL OVERALL DIMENSIONS ARE 72" X 21" APPROXIMATELY.

SEATS ARE MADE FROM 3/4" #9 EXPANDED METAL INSIDE A 2" X 3/4" X 1/8" ANGLE IRON FRAME. ALL CENTER BRACES ARE MADE FROM 1/4" X 1 1/2" FLAT STEEL.

FRAMES ARE MADE OF 2 3/8" HEAVY GALVANIZED STEEL TUBING THAT IS GALVANIZED INSIDE AND OUT AND MEETS OR EXCEEDS YIELD AND TENSILE OF SCH. 40 PIPE. CONSTRUCTED SO AS TO PROHIBIT RAIN WATER FROM COLLECTING AT GROUND LEVEL. COATED WITH A BAKED ON POLYESTER POWDER COAT FINISH.

ALL HARDWARE IS NON-CORROSIVE.  
WEIGHT FOR THE B6WBULP IS 113 LBS.

## MAINTENANCE

To maintain luster it is recommended to wash, rinse, and dry the units after prolonged use. Check for loose bolts and nuts and tighten as needed. Contact the factory for genuine Webcoat part replacements if needed.