



P.O. BOX 1520 WAUSAU, WI 54402-1520
 800-338-6728
 E-MAIL: WTL@WAUSAUTILE.COM
 WEB SITE: WWW.WAUSAUTILE.COM

REVISIONS

NO.	NAME	DATE	NOTES
1			
2			
3			
4			
5			
6			
7			
8			

CONFIDENTIAL INFORMATION
 THESE DRAWING, SPECIFICATIONS AND
 OTHER INFORMATION AND DOCUMENTS
 ACCOMPANYING THEM ARE THE
 CONFIDENTIAL AND PROPRIETARY PROPERTY
 OF WAUSAU TILE, INC. THE DRAWINGS
 THEMSELVES SHALL BELONG TO THE
 OWNER FOR USE ONLY ON THE PROJECT.
 ANY ADDITIONAL USE SHALL REQUIRE THE
 PRIOR WRITTEN APPROVAL OF WAUSAU
 TILE, INC. THE PROPRIETARY INFORMATION
 CONTAINED WITHIN THE DRAWINGS AND
 THE DOCUMENTS IS AND SHALL REMAIN
 THE SOLE PROPERTY OF WAUSAU TILE, INC.

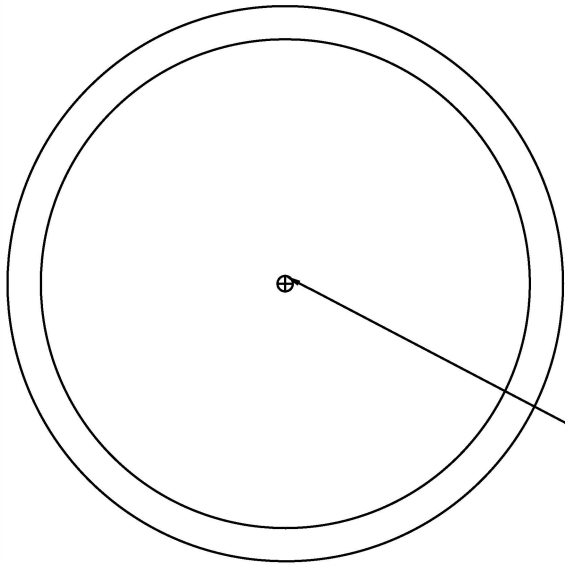

1 TOP VIEW

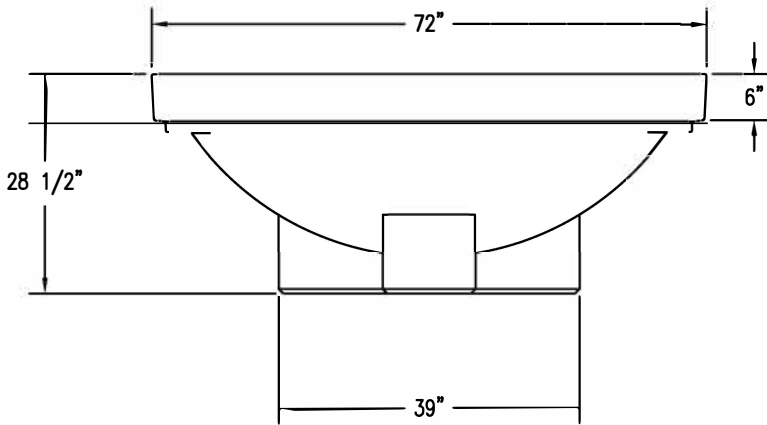

2 ELEVATION VIEW

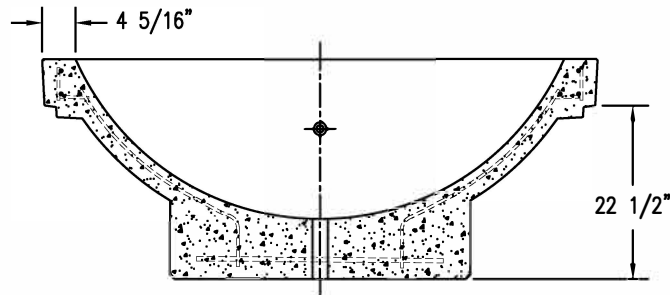

4 CROSS SECTION

2" DRAIN HOLE

(4) 1/2-13
 UNC S/S
 INSERTS

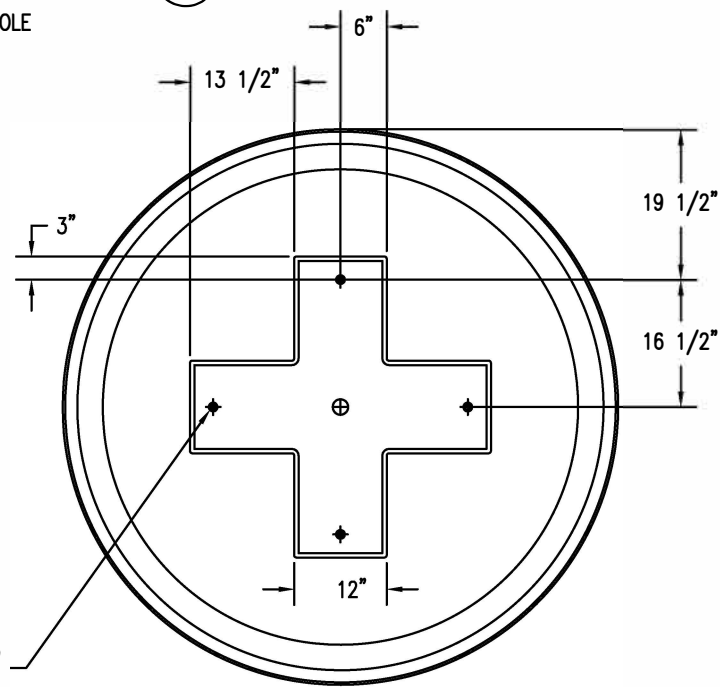

3 BOTTOM VIEW

JOB NAME _____
 ADDRESS _____
 CITY, STATE ZIP _____

UNLESS OTHERWISE SPECIFIED
 DIMENSIONS ARE IN INCHES
 FRACTIONS ±1/8"

DRAWN BY: SK
 DATE: 6/30/15
 CD NUMBER: ?
 WEIGHT: 2,300 LBS

PRODUCT NO.
 SL 4031