

1 5/16" O.D. GALV.
HIGH TENSILE TUBE

2 3/8" O.D. GALVANIZED HIGH
TENSILE TUBE FOR LONGER
LIFE.

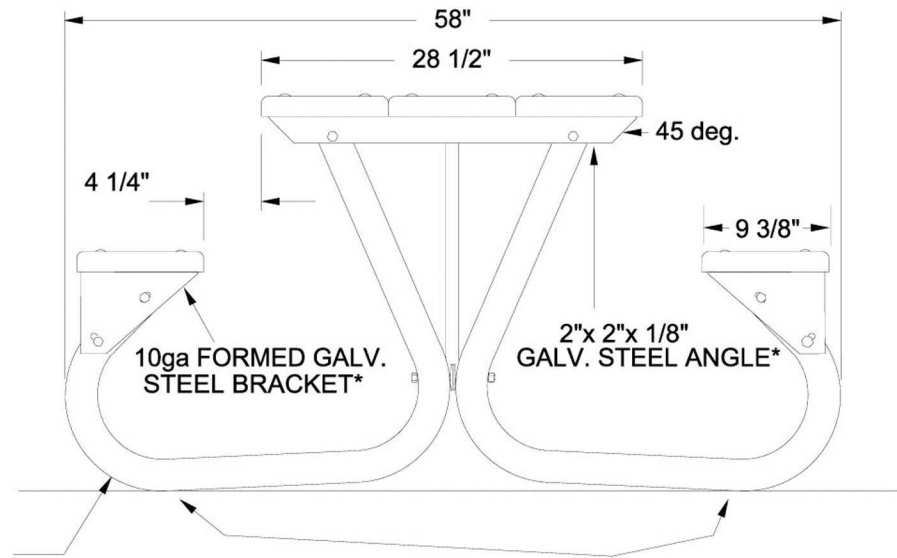

THE TABLE RESTS ON THE FOUR OUTSIDE CORNERS
SO THAT IT WILL NOT ROCK ON UNEVEN GROUND.

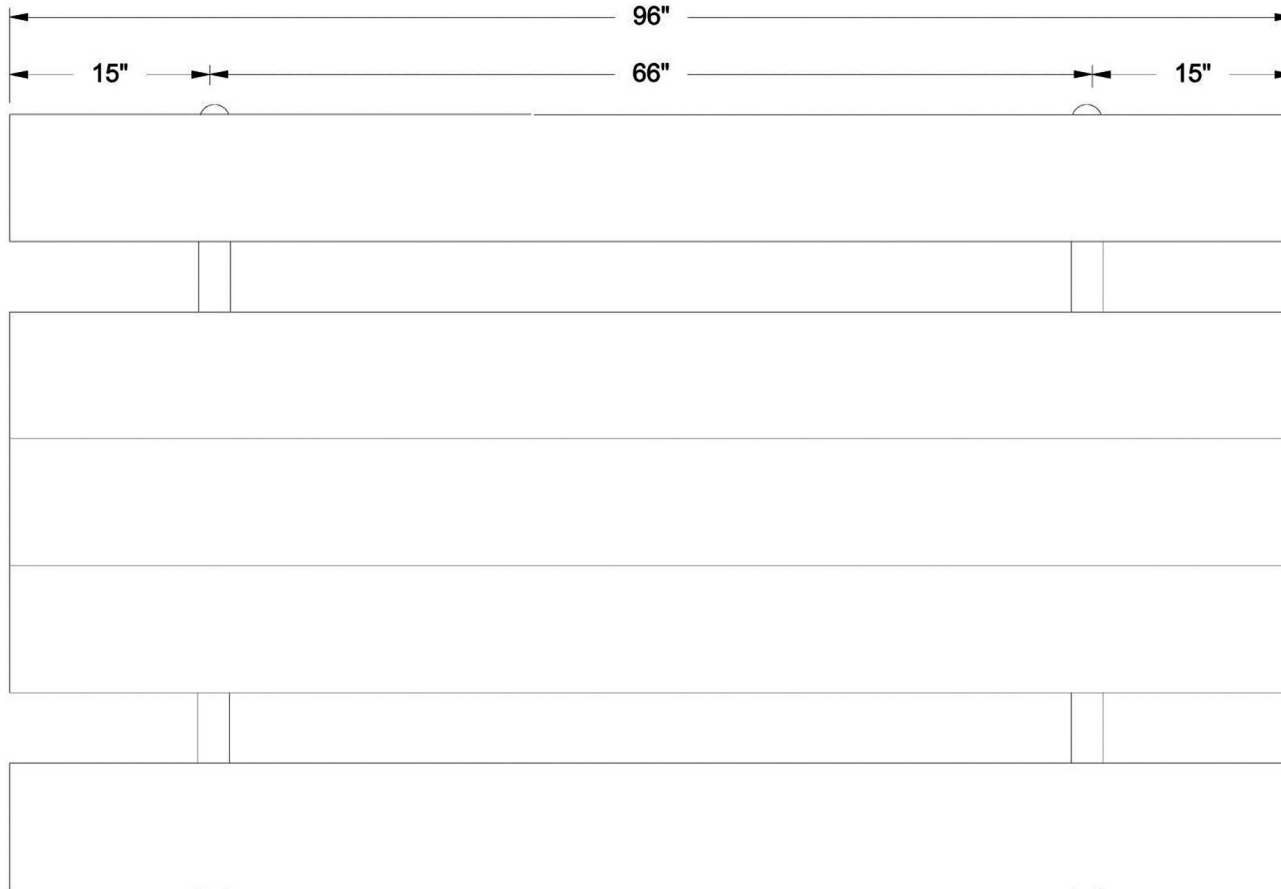

* SEAT BRACKET & TOP CLEAT ARE GALVANIZED
AFTER FABRICATION TO ELIMINATE RAW EDGES
LEFT WHEN USING PRE-GALV. SHEETS

← 2"x 10" (NOMINAL) 6063-T6 204-R1 CLEAR ANODIZED
ALUMINUM PLANKS W/ MATCHING END CAPS

FURNITURE LEISURE INC

OUR LIST OF WEB STORES

www.FurnitureLeisure.com
www.PicnicFurniture.com
www.ParkTables.com

www.PoolFurnitureSupply.com
www.PicnicTableSupplier.com
www.UBrace.com

1.800.213.2401

| | | | | | |
|----------|--------------|------|--------|-----------------|------|
| MODEL | 82BGA | | WT. | 151 lbs. | |
| DRAWN BY | LCB | DATE | 3/9/98 | SCALE | NONE |