

Material Specifications and Notes:

1. All structural steel tubing shall be ASTM A-500 Grade B-C
2. All other steel (plates, gussets, etc.) shall be ASTM A-36.
3. All welding is to be done in accordance with the latest AWS standards.
4. Standard bolts to be ASTM A-325 & threaded rod to be ASTM B-7 unless otherwise noted.
5. All fabricated steel & structural tubes are blasted to a near-white condition prior to application of primer and top coat.
 - Primer: Zinc Rich
 - Top coat: TGIC powder coating
6. Metal roofing shall be pre-cut 24ga. x 1 1/4" dp x 36" wide, Fy =50ksi steel panels.

Erection Notes:

All members must be properly braced until the complete structural system has been constructed. Bracing material and method is the responsibility of the G.C.

This building has been designed as a free standing, open structure. If walls or other modifications are to be made, the structure must be re-engineered prior to these modifications.

This document contains proprietary information and is not to be reproduced without the written permission from SUPERIOR RECREATIONAL PRODUCTS and/or is not to be used in any manner detrimental to the interest of SUPERIOR RECREATIONAL PRODUCTS.

N.I.C. = NOT IN CONTRACT
G.C. = GENERAL CONTRACTOR



Furniture Leisure
 Commercial Site Furnishings

FurnitureLeisure.com PoolFurnitureSupply.com
 PicnicFurniture.com PicnicTableSupplier.com
 ParkTables.com UBrace.com

1-800-213-2401 | sales@furnitureleisure.com

Table of Contents	
Page #	Description
1	General Specs and Notes
2	Primary Structural Views
3	Ground Plan Layout
4	Footer/Anchor Illustration

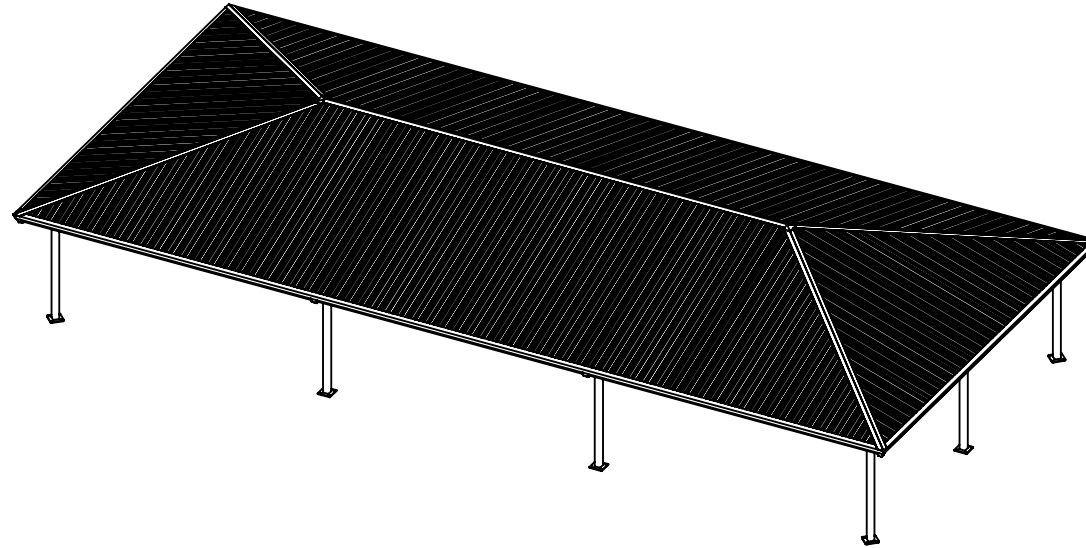

Model #: HE3064-AS
 30'-0" x 64'-0" Hip End Shelter
 7'-6" Eave Height
 4:12 Pitch

Preliminary Drawings

All quotation drawings are preliminary only, not to be used for installation of any kind.

Rev Date & Description:		THIS DOCUMENT AND THE INFORMATION CONTAINED HEREIN IS THE EXCLUSIVE PROPERTY OF SUPERIOR RECREATIONAL PRODUCTS AND HAS BEEN PROVIDED TO YOU IN CONFIDENCE. THIS DOCUMENT AND THE INFORMATION HEREIN MAY NOT BE DISCLOSED OR PROVIDED TO ANY THIRD PARTY OR USED, COPIED, PHOTOGRAPHED OR OTHERWISE REPRODUCED WITHOUT PRIOR EXPRESS WRITTEN PERMISSION OF SUPERIOR RECREATIONAL PRODUCTS.	Description: General Specs and Notes					
Rev Date & Description:			Material:		Rev: xx	Drawing Number: HE3064-AS		
Date: 10/13/2015	Drawn By: DEB	Weight:		Size: A	Units: Inch	Tol: ±.0625 Unless Otherwise Specified	Scale: NTS	Sheet: 1 of 4

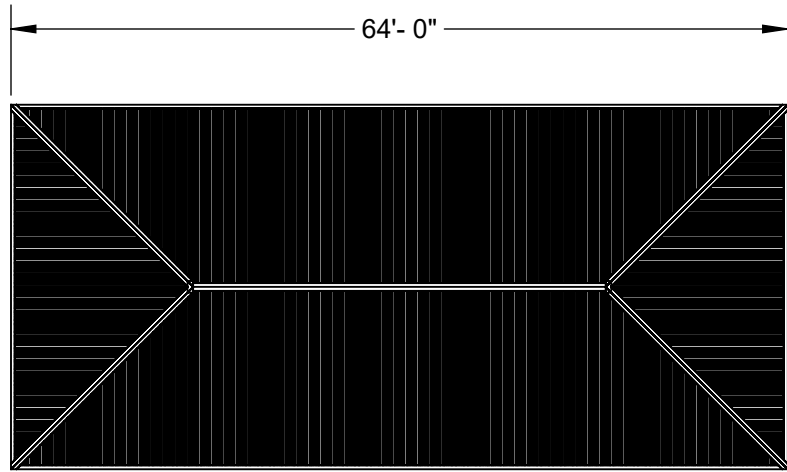

Top View

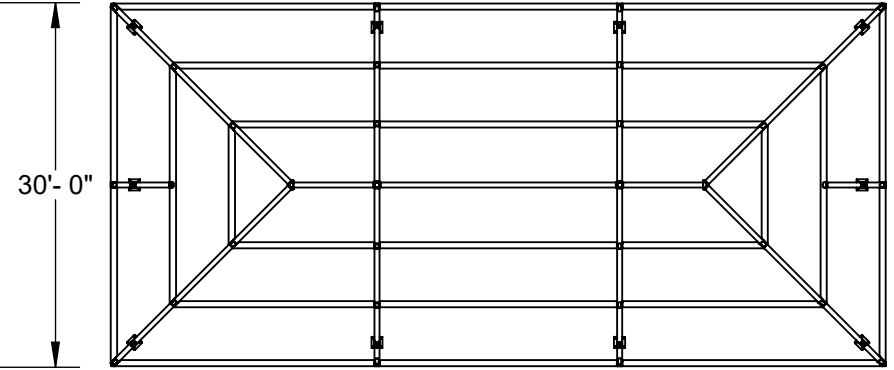

Top View (Frame Only)

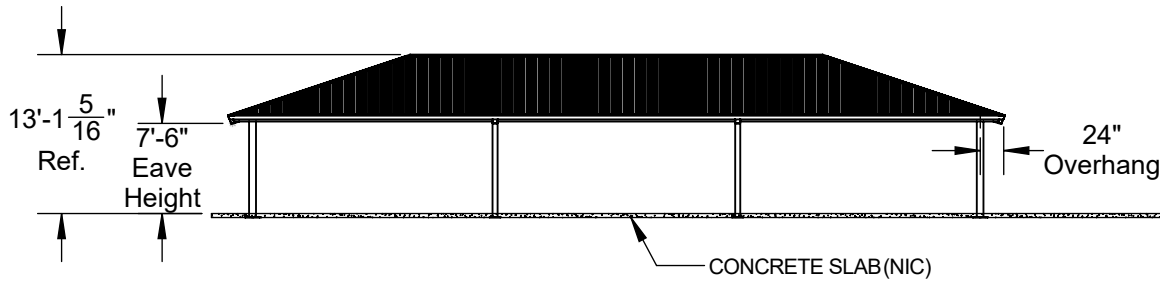

Front View

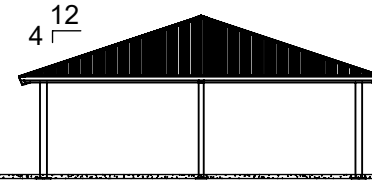

Side View

Preliminary Drawings

All quotation drawings are preliminary only, not to be used for installation of any kind.

Rev Date & Description:	
Rev Date & Description:	
Date: 10/13/2015	Drawn By: DEB

THIS DOCUMENT AND THE INFORMATION CONTAINED HEREIN IS THE EXCLUSIVE PROPERTY OF SUPERIOR RECREATIONAL PRODUCTS AND HAS BEEN PROVIDED TO YOU IN CONFIDENCE. THIS DOCUMENT AND THE INFORMATION HEREIN MAY NOT BE DISCLOSED OR PROVIDED TO ANY THIRD PARTY OR USED, COPIED, PHOTOGRAPHED OR OTHERWISE REPRODUCED WITHOUT PRIOR EXPRESS WRITTEN PERMISSION OF SUPERIOR RECREATIONAL PRODUCTS.

Description: Primary Structural Views					
Material:			Rev: xx	Drawing Number: HE3064-AS	
Weight:	Size: A	Units: Inch	Tol: + .0625 Unless Otherwise Specified	Scale: NTS	Sheet: 2 of 4

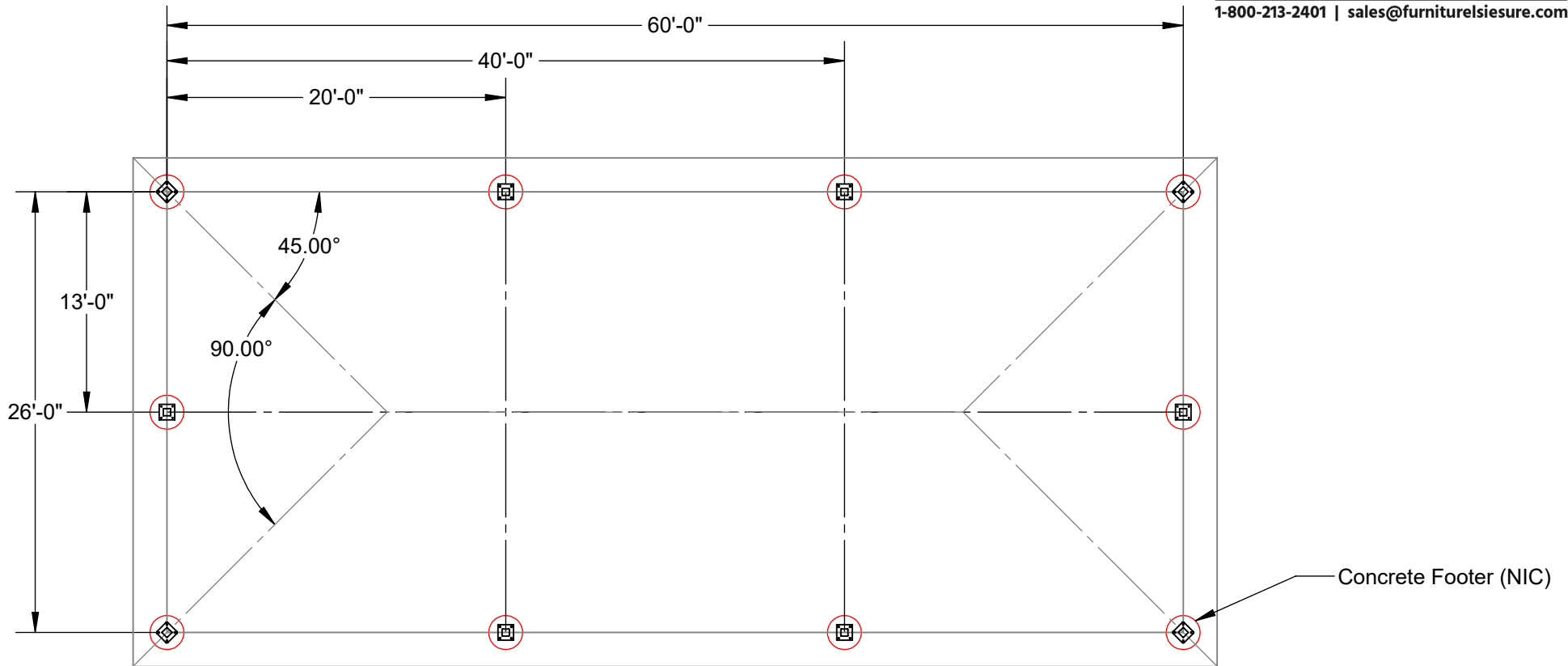

Preliminary Drawings

All quotation drawings are preliminary only, not to be used for installation of any kind.

Rev Date & Description:		<small>THIS DOCUMENT AND THE INFORMATION CONTAINED HEREIN IS THE EXCLUSIVE PROPERTY OF SUPERIOR RECREATIONAL PRODUCTS AND HAS BEEN PROVIDED TO YOU IN CONFIDENCE. THIS DOCUMENT AND THE INFORMATION HEREIN MAY NOT BE DISCLOSED OR PROVIDED TO ANY THIRD PARTY OR USED, COPIED, PHOTOGRAPHED OR OTHERWISE REPRODUCED WITHOUT PRIOR EXPRESS WRITTEN PERMISSION OF SUPERIOR RECREATIONAL PRODUCTS.</small>	Description: Ground Plan Layout				
Rev Date & Description:			Material:		Rev: xx	Drawing Number: HE3064-AS	
Date: 10/13/2015	Drawn By: DEB		Weight:	Size: A	Units: Inch	Tol: ±.0625 Unless Otherwise Specified	Scale: NTS

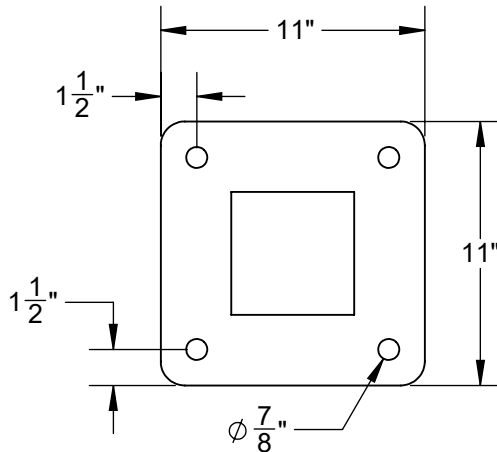
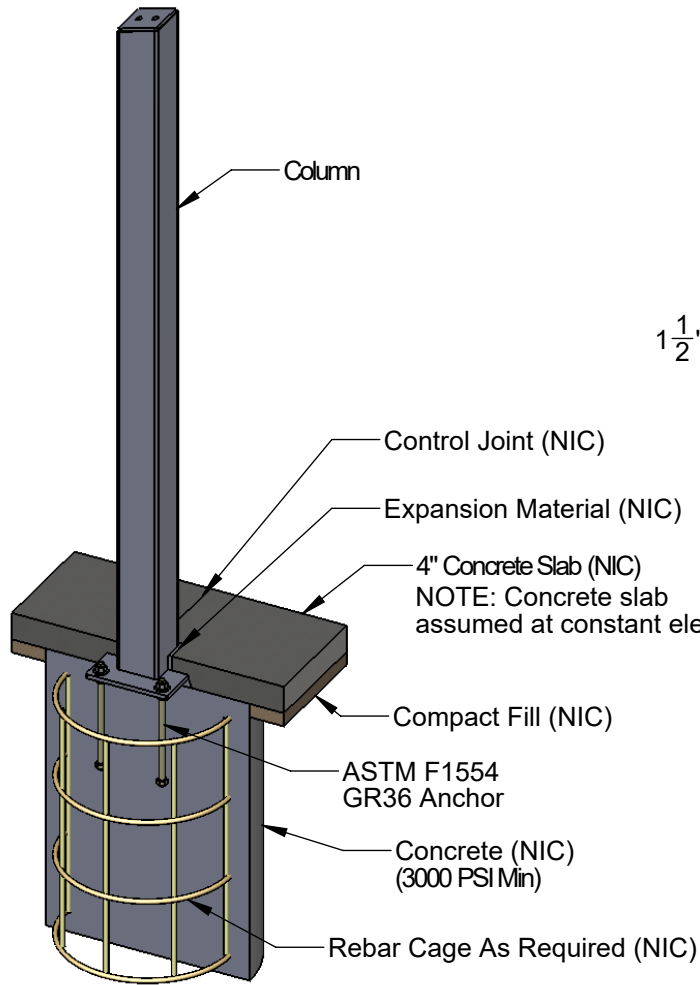

3/4" Base Plate

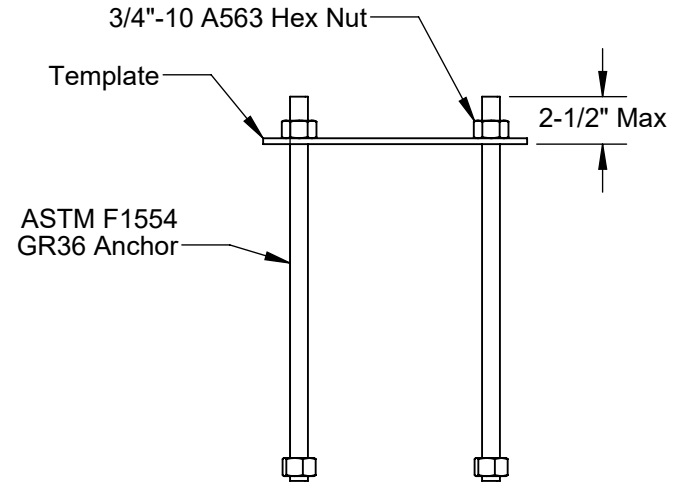

Anchor Bolt Template Assembly

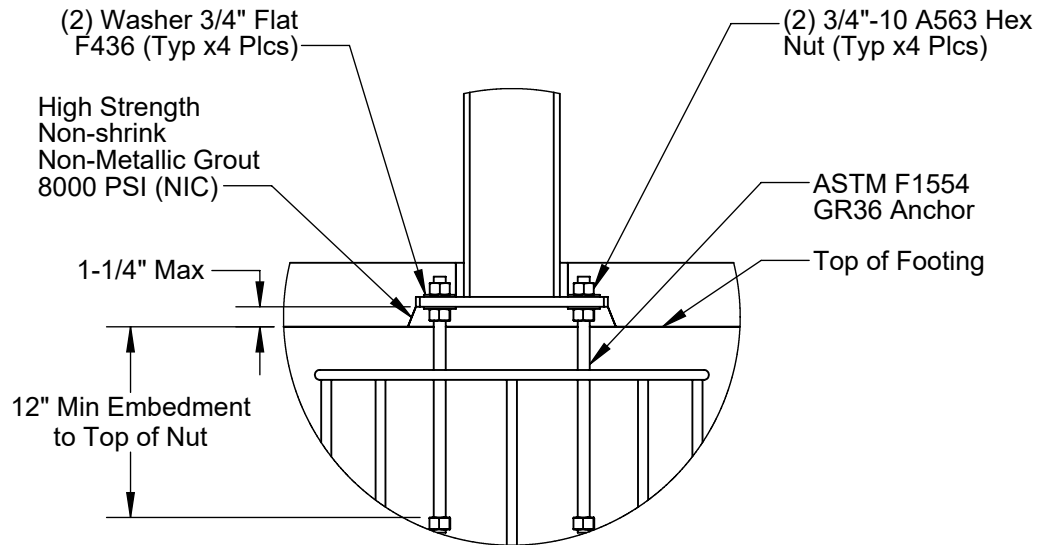

DESIGN NOTE:

All foundation design information should be considered as preliminary only. A local soils engineer shall be retained to design the foundation according to local conditions and codes. Final design of the footing/foundation is the responsibility of the general contractor/owner.

Preliminary Drawings

All quotation drawings are preliminary only, not to be used for installation of any kind.

Rev Date & Description:	
Rev Date & Description:	
Date: 10/13/2015	Drawn By: DEB

THIS DOCUMENT AND THE INFORMATION CONTAINED HEREIN IS THE EXCLUSIVE PROPERTY OF SUPERIOR RECREATIONAL PRODUCTS AND HAS BEEN PROVIDED TO YOU IN CONFIDENCE. THIS DOCUMENT AND THE INFORMATION HEREIN MAY NOT BE DISCLOSED OR PROVIDED TO ANY THIRD PARTY OR USED, COPIED, PHOTOGRAPHED OR OTHERWISE REPRODUCED WITHOUT PRIOR EXPRESS WRITTEN PERMISSION OF SUPERIOR RECREATIONAL PRODUCTS.

Description: Footer/Anchor Illustration					
Material:			Rev: xx	Drawing Number: HE3064-AS	
Weight:	Size: A	Units: Inch	Tol: ±.0625 Unless Otherwise Specified	Scale: NTS	Sheet: 4 of 4