

## Table of Contents

| Page # | Description                |
|--------|----------------------------|
| 1      | General Specs and Notes    |
| 2      | Primary Structural Views   |
| 3      | Ground Plan Layout         |
| 4      | Footer/Anchor Illustration |

**Material Specifications and Notes:**

1. All structural steel tubing shall be ASTM A-500 Grade B-C
2. All other steel (plates, gussets, etc.) shall be ASTM A-36.
3. All welding is to be done in accordance with the latest AWS standards.
4. Standard bolts to be ASTM A-325 & threaded rod to be ASTM B-7 unless otherwise noted.
5. All fabricated steel & structural tubes are blasted to a near-white condition prior to application of primer and top coat.
  - Primer: Zinc Rich
  - Top coat: TGIC powder coating
6. Metal roofing shall be pre-cut 24ga. x 1 1/4" dp x 36" wide, Fy =50ksi steel panels.

**Erection Notes:**

All members must be properly braced until the complete structural system has been constructed. Bracing material and method is the responsibility of the G.C.

This building has been designed as a free standing, open structure. If walls or other modifications are to be made, the structure must be re-engineered prior to these modifications.

This document contains proprietary information and is not to be reproduced without the written permission from SUPERIOR RECREATIONAL PRODUCTS and/or is not to be used in any manner detrimental to the interest of SUPERIOR RECREATIONAL PRODUCTS.

**N.I.C. = NOT IN CONTRACT**  
**G.C. = GENERAL CONTRACTOR**

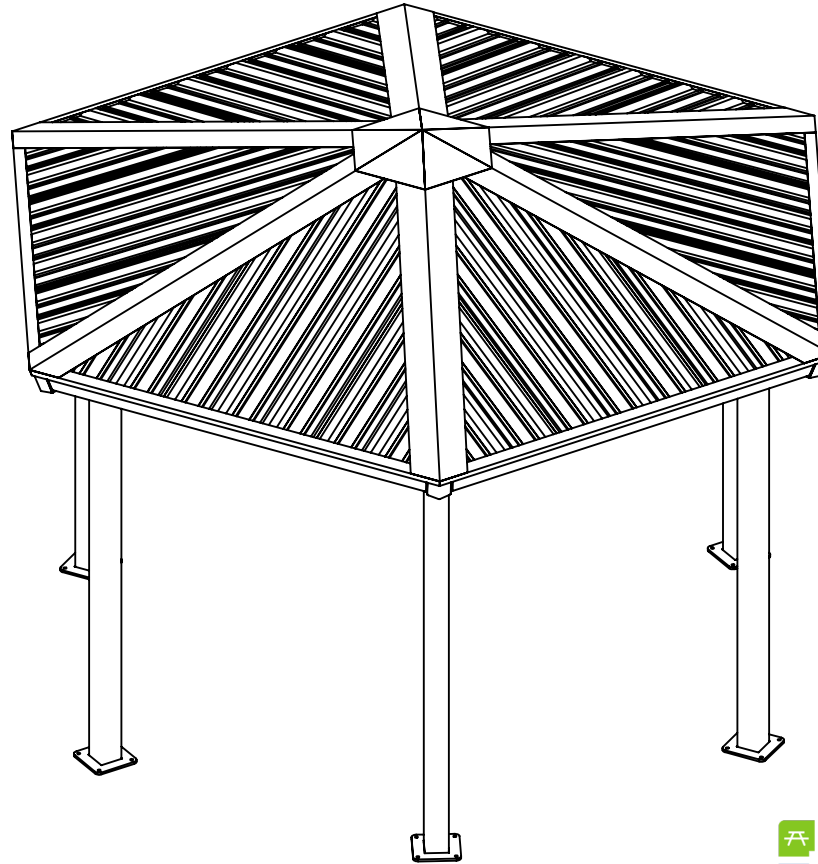

**Model #: 6S16-AS**  
**16' Square Shelter**  
**7'-6" Eave Height**  
**4:12 Pitch**

**Furniture Leisure**  
 Commercial Site Furnishings

[FurnitureLeisure.com](http://FurnitureLeisure.com)   [PoolFurnitureSupply.com](http://PoolFurnitureSupply.com)  
[PicnicFurniture.com](http://PicnicFurniture.com)   [PicnicTableSupplier.com](http://PicnicTableSupplier.com)  
[ParkTables.com](http://ParkTables.com)   [UBrace.com](http://UBrace.com)

1-800-213-2401 | [sales@furnitureleisure.com](mailto:sales@furnitureleisure.com)

## Preliminary Drawings

All quotation drawings are preliminary only, not to be used for installation of any kind.

|  |  |  |
|--|--|--|
| Rev Date & Description:<br><br>Rev Date & Description:<br><br>Date: _____ Drawn By: <b>SCB</b> | THIS DOCUMENT AND THE INFORMATION CONTAINED HEREIN IS THE EXCLUSIVE PROPERTY OF SUPERIOR RECREATIONAL PRODUCTS AND HAS BEEN PROVIDED TO YOU IN CONFIDENCE. THIS DOCUMENT AND THE INFORMATION HEREIN MAY NOT BE DISCLOSED OR PROVIDED TO ANY THIRD PARTY OR USED, COPIED, PHOTOGRAPHED OR OTHERWISE REPRODUCED WITHOUT PROIOR EXPRESS WRITTEN PERMISSION OF SUPERIOR RECREATIONAL PRODUCTS. | Description:<br><h2 style="text-align: center;">General Specs and Notes</h2>   |
|  |  | Material: _____ Rev: <b>xx</b> Drawing Number: <b>6S16-AS</b>  |
|  |  | Weight: _____ Size: <b>A</b> Units: <b>Inch</b> Tol: <b>±.0625 Unless Otherwise Specified</b> Scale: <b>NTS</b> Sheet: <b>1 of 4</b> |

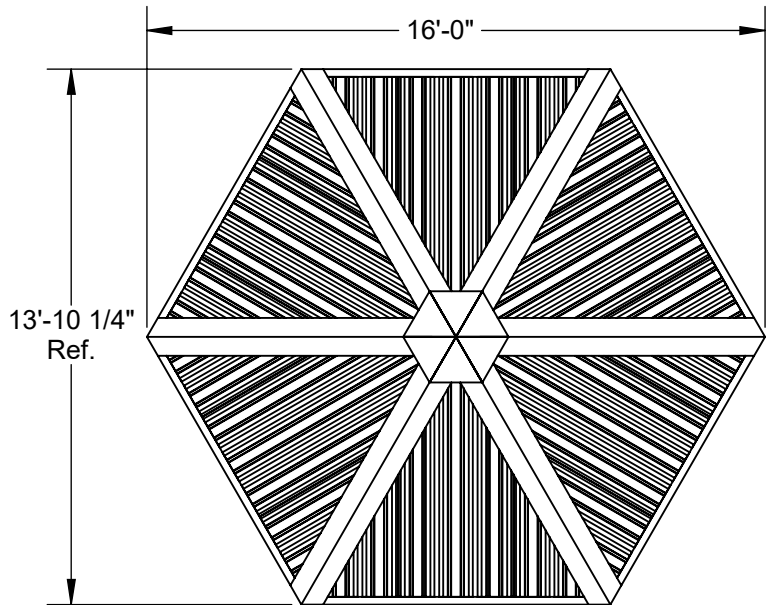

**Top View**

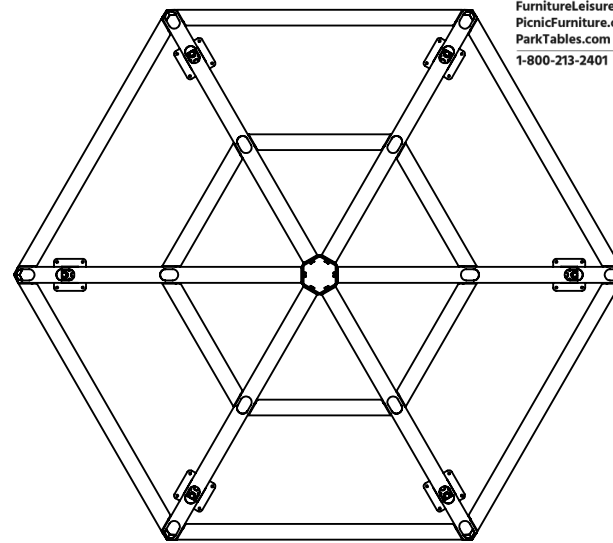

**Top View (Frame Only)**

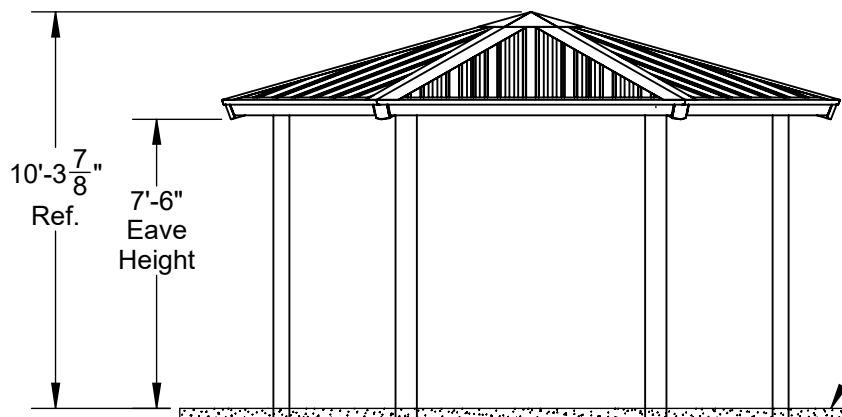

**Front View**

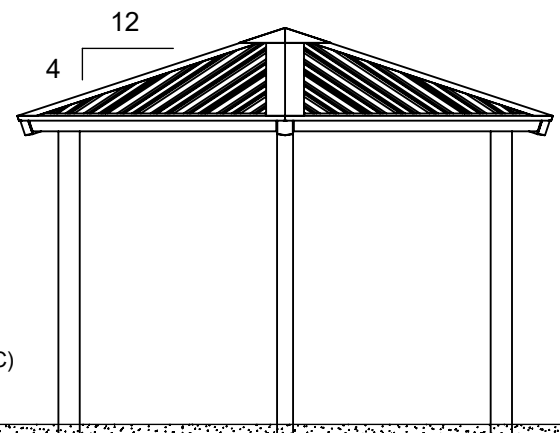

**Side View**

**Preliminary Drawings**

All quotation drawings are preliminary only, not to be used for installation of any kind.

|                         |                  |
|-------------------------|------------------|
| Rev Date & Description: |                  |
| Rev Date & Description: |                  |
| Date:<br>10/13/2015     | Drawn By:<br>SCB |

THIS DOCUMENT AND THE INFORMATION CONTAINED HEREIN IS THE EXCLUSIVE PROPERTY OF SUPERIOR RECREATIONAL PRODUCTS AND HAS BEEN PROVIDED TO YOU IN CONFIDENCE. THIS DOCUMENT AND THE INFORMATION HEREIN MAY NOT BE DISCLOSED OR PROVIDED TO ANY THIRD PARTY OR USED, COPIED, PHOTOGRAPHED OR OTHERWISE REPRODUCED WITHOUT PROIOR EXPRESS WRITTEN PERMISSION OF SUPERIOR RECREATIONAL PRODUCTS.

|   |                   |                       |  |                                   |                         |
|---|-------------------|-----------------------|--|-----------------------------------|-------------------------|
| Description:<br><b>Primary Structural Views</b> |                   |                       |  |                                   |                         |
| Material:                                       |                   |                       | Rev:<br><b>xx</b>                            | Drawing Number:<br><b>6S16-AS</b> |                         |
| Weight:   | Size:<br><b>A</b> | Units:<br><b>Inch</b> | Tol:<br>±.0625<br>Unless Otherwise Specified | Scale:<br><b>NTS</b>              | Sheet:<br><b>2 of 4</b> |

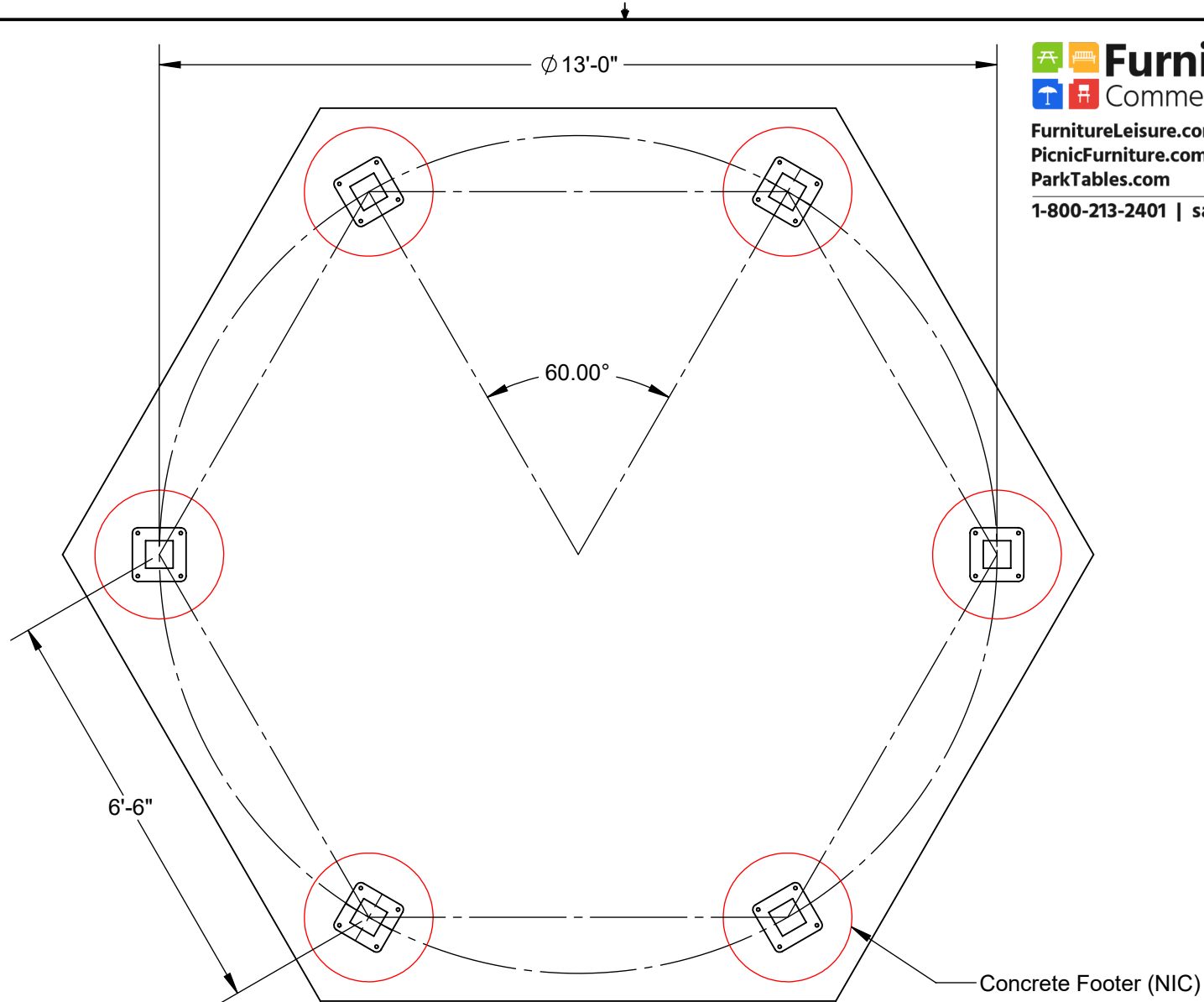

## Preliminary Drawings

All quotation drawings are preliminary only, not to be used for installation of any kind.

Rev Date & Description:

Rev Date & Description:

Date: 10/13/2015

Drawn By: SCB

THIS DOCUMENT AND THE INFORMATION CONTAINED HEREIN IS THE EXCLUSIVE PROPERTY OF SUPERIOR RECREATIONAL PRODUCTS AND HAS BEEN PROVIDED TO YOU IN CONFIDENCE. THIS DOCUMENT AND THE INFORMATION HEREIN MAY NOT BE DISCLOSED OR PROVIDED TO ANY THIRD PARTY OR USED, COPIED, PHOTOGRAPHED OR OTHERWISE REPRODUCED WITHOUT PROIOR EXPRESS WRITTEN PERMISSION OF SUPERIOR RECREATIONAL PRODUCTS.

Description:

Ground Plan Layout

Material:

Rev: xx

Drawing Number: 6S16-AS

Weight:

Size: A

Units: Inch

Tol:  $\pm .0625$   
Unless Otherwise Specified

Scale: NTS

Sheet: 3 of 4

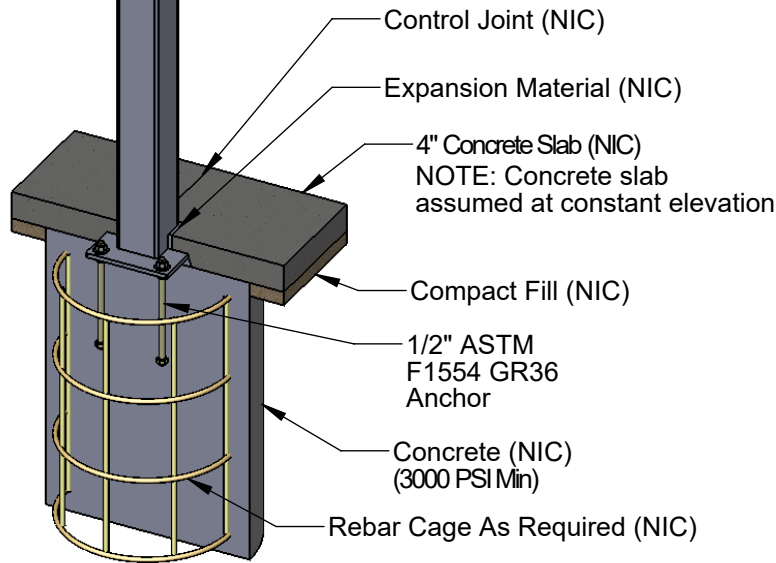
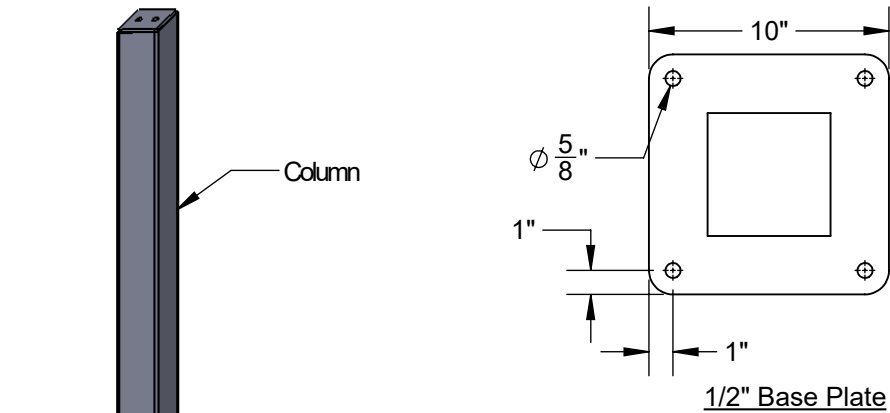

**DESIGN NOTE:**

All foundation design information should be considered as preliminary only. A local soils engineer shall be retained to design the foundation according to local conditions and codes. Final design of the footing/foundation is the responsibility of the general contractor/owner.

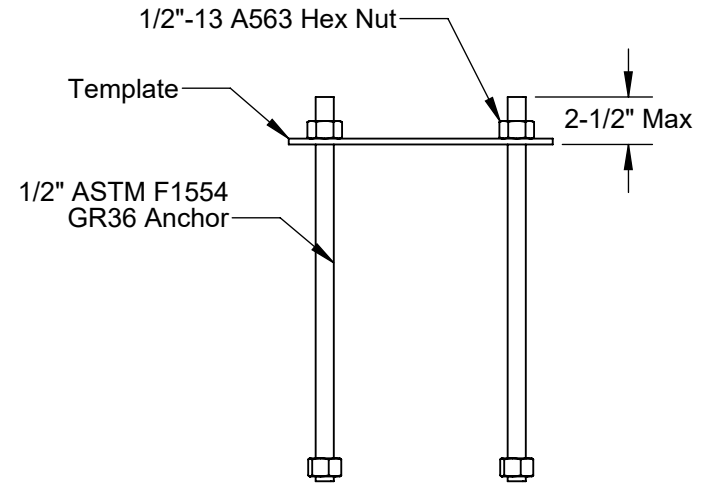

Anchor Bolt Template Assembly

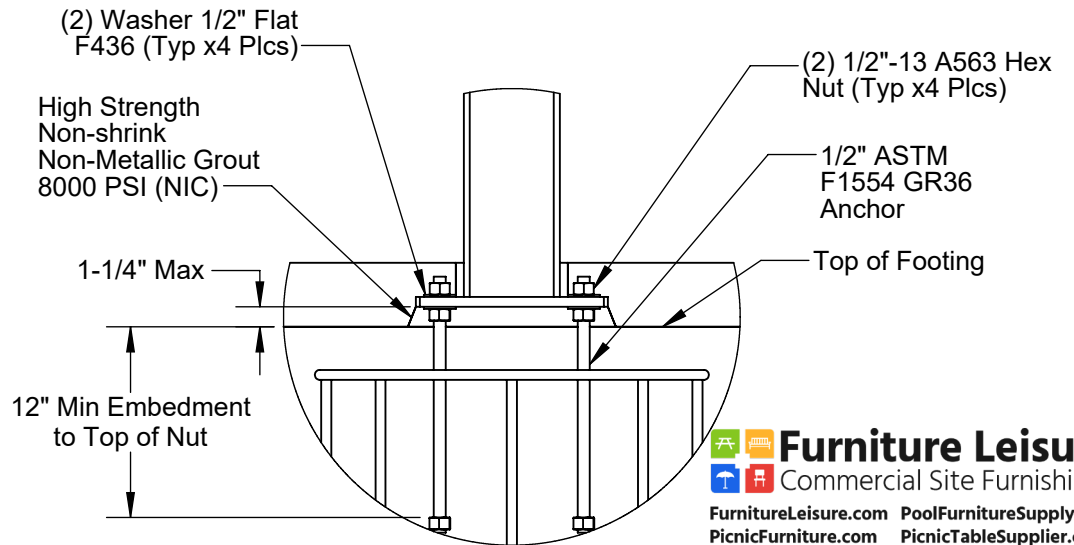

**Furniture Leisure**  
 Commercial Site Furnishings  
 FurnitureLeisure.com PoolFurnitureSupply.com  
 PicnicFurniture.com PicnicTableSupplier.com  
 ParkTables.com UBrace.com  
 1-800-213-2401 | sales@furnitureleisure.com

**Preliminary Drawings**

All quotation drawings are preliminary only, not to be used for installation of any kind.

|                         |                  |   |   |            |                |  |                      |                  |
|-------------------------|------------------|---|---|------------|----------------|--|----------------------|------------------|
| Rev Date & Description: |                  | THIS DOCUMENT AND THE INFORMATION CONTAINED HEREIN IS THE EXCLUSIVE PROPERTY OF SUPERIOR RECREATIONAL PRODUCTS AND HAS BEEN PROVIDED TO YOU IN CONFIDENCE. THIS DOCUMENT AND THE INFORMATION HEREIN MAY NOT BE DISCLOSED OR PROVIDED TO ANY THIRD PARTY OR USED, COPIED, PHOTOGRAPHED OR OTHERWISE REPRODUCED WITHOUT PRIOR EXPRESS WRITTEN PERMISSION OF SUPERIOR RECREATIONAL PRODUCTS. | Description:<br><b>Footer/Anchor Illustration</b> |            |                |  |                      |                  |
| Rev Date & Description: |                  |   | Material:   |            | Rev: <b>xx</b> | Drawing Number:<br><b>6S16-AS</b>            |                      |                  |
| Date:<br>10/13/2015     | Drawn By:<br>SCB |   | Weight:   | Size:<br>A | Units:<br>Inch | Tol:<br>±.0625<br>Unless Otherwise Specified | Scale:<br><b>NTS</b> | Sheet:<br>4 of 4 |