

LEAVE ALL BOLTS LOOSE UNTIL ALL ARE IN PLACE.

1. BOLT THE LEGS TOGETHER AS SHOWN WITH THE BRACE BETWEEN THE LEGS, AND THE TOP ANGLE AND SEAT ANGLES FACING THE SAME WAY. NOTICE THERE IS A LEFT AND RIGHT SEAT ANGLE. ATTACH APPROPRIATELY. THE BENT END OF BRACE POINTS AWAY FROM THE LEG.
2. LAY FIBERGLASS TOP UPSIDE DOWN ON A NON-ABRASIVE SURFACE. SET A TABLE LEG ON THE TABLE TOP. LINE UP THE TOP ANGLE HOLES WITH THE PREDRILLED PILOT HOLES. NOTE: YOU MAY NEED TO TAP THE 3/8" x 2" LAG SCREW WITH A HAMMER IN ORDER TO START THE SCREW INTO THE PILOT HOLE.
3. CONNECT THE BRACES TO THE PREDRILLED CENTER HOLE(S).
4. ATTACH THE SEAT PLANKS W/ THE 3/8" x 2" LAG SCREW.

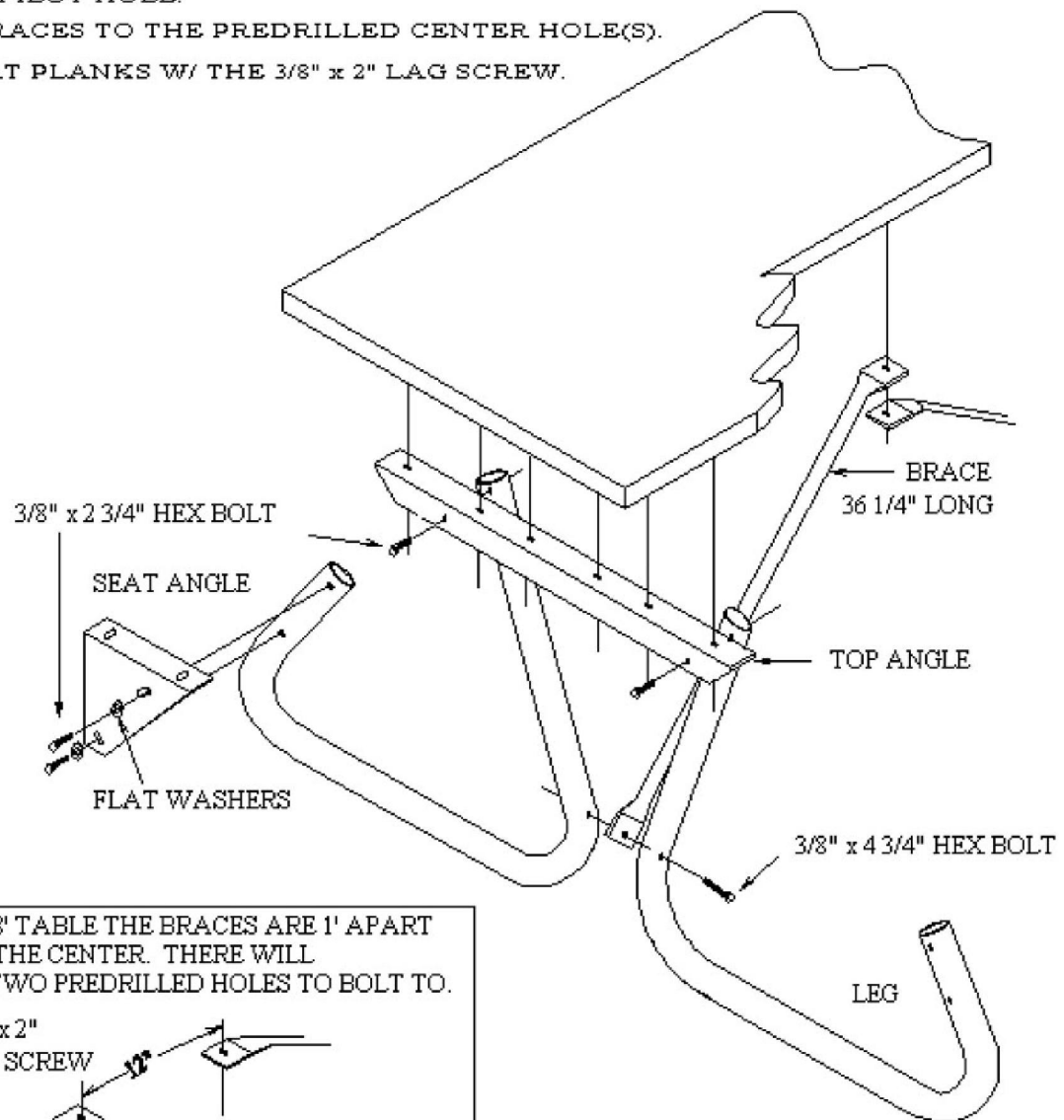

ON 8' TABLE THE BRACES ARE 1' APART AT THE CENTER. THERE WILL BE TWO PREDRILLED HOLES TO BOLT TO.

3/8" x 2"
LAG SCREW

