

Model Numbers:  
 TOT46-B-04-012 - Advantage Coating  
 TOT46-D-04-012 - Industry Standard Coating

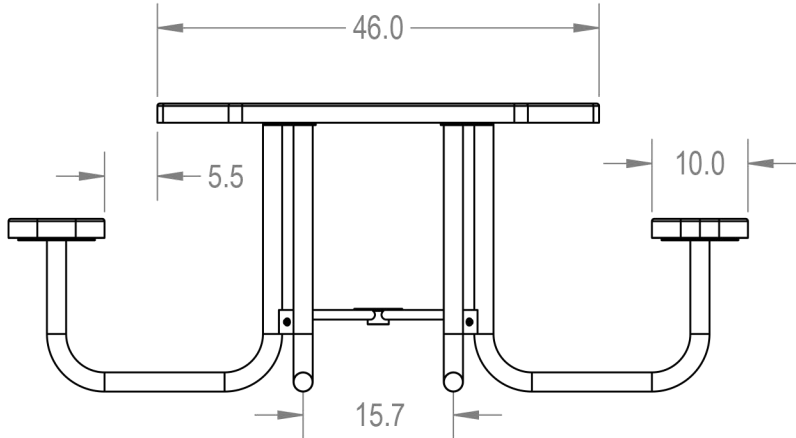
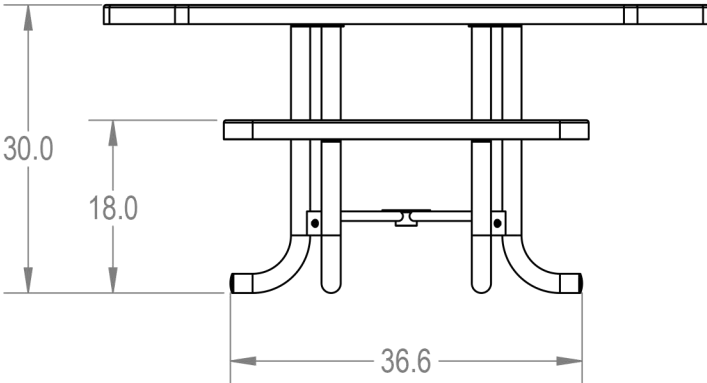
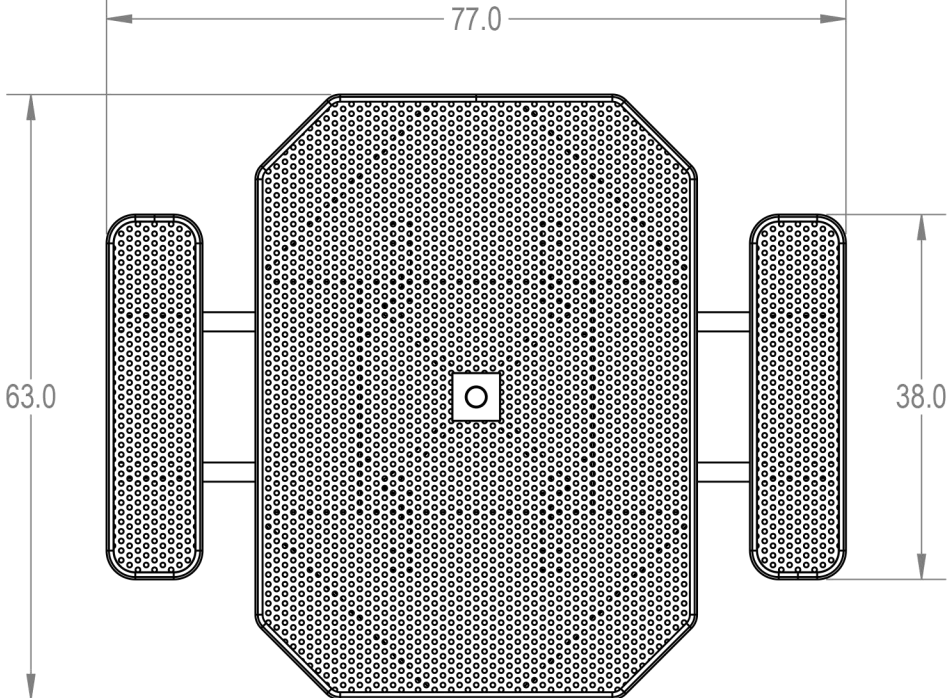

	NAME	DATE	<b>AAdvantage Panels &amp; Fence, Inc.</b>	
DRAWN	GM	2/13/2016	TITLE:	
SALES APPR.			46" Octagon Top Table - 2 Seat - Portable	
CLIENT APPR.			<b>Perforated Metal Version</b>	
MFG APPR.			SIZE	DWG. NO.
Q.A.			<b>A</b>	REV
Design By -			WEIGHT:	
CADWorksPro Chicago, IL			SHEET 3 OF 3	
www.cadworkspro.com				

**FURNITURE LEISURE INC**  
 1.800.213.2401 | SALES@FURNITURELEISURE.COM

FurnitureLeisure.com  
 PicnicFurniture.com  
 ParkTables.com

PoolFurnitureSupply.com  
 PicnicTableSupplier.com  
 UBrace.com